

LINCOLN COUNTY, NV

2019-156791

\$35.00

08/01/2019 03:35 PM

Rec:\$35.00

FA NV DIRECT TITLE

Pgs=36 KE

OFFICIAL RECORD

AMY ELMER, RECORDER

APN# 004-141-75

When recorded, return to:
Synergy One Lending, Inc,
Attn: Final Document Department,
C/O Doc Probe,
1125 Ocean Avenue,
Lakewood, NJ, 08701

File # 2562016

LOAN #: 12031809861

RESIDENTIAL CONSTRUCTION LOAN AGREEMENT

MIN: 1012096-0000040370-1

THIS CONSTRUCTION LOAN AGREEMENT (this "Loan Agreement") is made on **July 29, 2019**
by and between **Michael Q. Walsh**

(the "Borrower"), whose address is **P.O. Box 396, Alamo, NV 89001**

and **Synergy One Lending, Inc, a Corporation**

and its successors and/or assigns (the "Lender"), whose address is **3131 Camino Del Rio North,
Suite 190, San Diego, CA 92108.**

In this Loan Agreement, "you" and "your" refer to the Borrower, and "we", "us" and "our" refer to the Lender.

Multistate - Residential Construction Loan Agreement (Construction/Permanent Loan)
Elle Mae, Inc. Page 1 of 13

GCNSTPAGR 0317
GCNSTPAGL (CLS)



RECITALS:

- A. You own or are purchasing certain real property described in Exhibit A attached to this Loan Agreement (the "Property") and propose to construct a residence building and related improvements thereon (the "Improvements").
- B. We have agreed to make a loan to you to finance the purchase of the Property (if applicable) and to construct the Improvements in the principal sum of **\$349,200.00** (the "Loan"), as evidenced by that certain promissory note of this date issued by you to us and any riders thereto (the "Note") and secured by a deed of trust, mortgage or similar security instrument from you for our benefit, encumbering the Property, and any riders thereto (the "Security Instrument").
- C. We are entering into this Loan Agreement to set forth the terms and conditions by which we will advance the proceeds of the Loan to you (the "Loan Proceeds") for the construction of the Improvements.

AGREEMENTS:

- 1. **Definitions.** In this Loan Agreement, the following terms shall have the meanings indicated:
 - (a) "Borrower Funds" means an amount equal to the difference, if any, between the estimated total cost of the Improvements and the Loan Proceeds allocated in the Budget for the financing of the Improvements.
 - (b) "Budget" means the construction budget heretofore approved by us attached hereto as Exhibit B.
 - (c) "Construction Completion Date" means **December 31, 2019** being the date on which the construction of the Improvements must be completed in all material respects so as to permit us to make the final disbursement of the Loan Proceeds to you.
 - (d) "Construction Contract" means the contract for the construction of the Improvements between you and the Contractor dated **April 18, 2019**.
 - (e) "Construction Period" means the period of time from the date hereof until the Completion Date.
 - (f) "Contractor" means
 - Borrower is acting as Contractor thus, any reference to Contractor herein shall mean Borrower, and any obligations of Contractor shall be obligations required of Borrower.
 - Muddy River Contractor**
My Contractor. At or before closing of the Loan, I have entered into a written agreement ("Construction Contract") with **Muddy River Contractor**
("Contractor") with offices at **460 N MV BLVD, Overton, NV 89040**
for all the Work.
 - (g) "Draw Request" means the Draw Request and Disbursement Authorization in the form attached hereto as Exhibit C.
 - (h) "Draw Schedule" means the schedule pursuant to which we will disburse the Loan Proceeds to you which is attached hereto and made a part hereof as Exhibit D.
 - (i) "Holdback" means an amount equal to **N/A** of the Loan Proceeds which we will retain and not disburse until the completion of construction of the Improvements. You acknowledge that the Holdback will not be available to fund construction of the Improvements as construction progresses; but, it will be held by us and not disbursed until all conditions for the final disbursement of the Loan Proceeds have been satisfied.
 - (j) "Loan Documents" means the Note, the Security Instrument, this Loan Agreement, Assignments of the Construction Contract and the Plans, an Assignment of Contracts, Licenses, Permits and Warranties, and any other documents pertaining to the Loan.
 - (k) "Plans" means the plans and specifications for the Improvements heretofore approved by us and by all governmental authorities whose approval is required in order to commence construction of the Improvements.
 - (l) "Title Company" means the title insurance company that issues the Lender's title insurance policy on the Property to us as required in this Loan Agreement.



LOAN #: 12031809861

2. Borrower's Obligation. You shall, within twenty (20) days from the date of this Loan Agreement, obtain and provide copies, certified if requested by us, of (a) all building permits or equivalent permits if the building permit is issued in stages, (b) all approvals, consents, and permits of any governmental authority, (c) all approvals which may be required under any recorded covenants, restrictions or conditions, and (d) permits for water, gas, electricity and storm and sewage disposal utilities. Thereafter, you shall cause the construction of the Improvements to be commenced not later than thirty (30) days from the date of recordation of the Security Instrument and to be completed with due diligence in such manner so that all conditions to the final disbursement of the Loan Proceeds shall have been satisfied and the final advance shall have been made by no later than the Completion Date.

3. Use of Loan Proceeds. We shall disburse to you or on your behalf an amount not to exceed the total amount of the Loan in accordance with the terms of this Loan Agreement and pursuant to the Draw Schedule. You agree that the Loan Proceeds shall be used for the purchase of the Property (if applicable), to pay off any current liens against the Property (if applicable) and the construction of the Improvements as provided in the Plans, in accordance with the Budget and pursuant to the Construction Contract. Any Loan Proceeds that remain after all disbursements have been made hereunder shall be credited by us, as a partial prepayment by you, against the principal balance owing under the Note.

4. Borrower's Equity. You acknowledge and agree that you must deposit the Borrower Funds with us before we shall have any obligation to disburse any portion of the Loan Proceeds. Any Borrower Funds placed with us will be drawn upon and used to fund the costs of construction prior to any advances being made under this Loan Agreement. Additionally, to the extent permitted by applicable law, you agree that the Borrower Funds may be used by us to offset any amounts owing to us under the Loan Documents upon an Event of Default. You further agree that, unless otherwise required by applicable law, you shall not be entitled to interest or other earnings on the Borrower Funds. If at any time during the course of construction of the Improvements it is determined by us in our sole discretion that the total cost to complete the Improvements exceeds the Loan Proceeds remaining to be disbursed by us, you agree that, upon our request, you shall deposit with us an amount equal to such difference prior to any further disbursement of the Loan Proceeds.

5. Conditions Precedent for Making Disbursements. Our obligation to make the initial and each subsequent disbursement under this Loan Agreement is conditioned upon there being delivered to us, in form and substance satisfactory to us, the following:

- (a) Execution and delivery to us by you of the Loan Documents.
- (b) Evidence satisfactory to us that: (i) the Loan Proceeds are sufficient to pay the costs of construction remaining to be performed in accordance with the Budget and Plans, and (ii) our security interest remains in a first priority position on the Property (including, but not limited to, affidavits from you, contractors, architects, and others, certifying that work has not been done on or with respect to the Property or the Improvements before the date of recordation of the Security Instrument).
- (c) A mortgagee's or lender's policy of title insurance in form and substance satisfactory to us, together with such title insurance endorsements to the said policy as we may require, including any endorsements insuring the continued priority of the Security Instrument over any and all liens (including, without limitation, mechanics' liens). Without limiting the foregoing, if required by us, you shall provide to us and pay for an endorsement prior to the payment of each interim disbursement.
- (d) A policy of general homeowners insurance and/or course of construction casualty insurance, in the form of an "all risk" policy with fire, extended coverage, builder's risk, general liability and worker's compensation (unless waived), replacement cost, vandalism, and malicious mischief insurance coverage. Builder's risk insurance obtained by the Contractor may be acceptable to Lender in lieu of "course of construction insurance" provided that such insurance meets all requirements of this Loan Agreement and we approve such substitution.
- (e) Evidence satisfactory to us that the Property is not situated in an area designated by the Federal Emergency Management Agency as being located in a special flood hazard area and, if the Property is located in a special flood hazard area, evidence that you have submitted a flood insurance application in the amount and form acceptable to us.
- (f) Copies of all permits and approvals required for the construction and use of the Improvements (including, but not limited to, building permits, grading permits, water management approvals, plan approvals, utility allocations, etc.) and evidence that all applicable environmental requirements have been met.
- (g) Evidence satisfactory to us that the Plans have been approved by applicable homeowners association, subdivision planning or architectural review committees, if applicable.



LOAN #: 12031809861

(h) A boundary survey of the Property acceptable in all respects and certified to us and the Title Company. Upon completion of the foundation for the Improvements, the survey must be updated in a manner acceptable to us and the Title Company showing that the Improvements will be constructed entirely upon the Property and not encroach upon any easement areas or violate any setbacks or other restrictions applicable to the Property.

(i) Letters dated within 30 days of closing from the appropriate utility service companies that indicate that water, sewer, electricity and gas (if applicable) are available to the Property in sufficient quantity to serve the Improvements. The letters from the companies supplying water and sewer must certify that the Plans are in compliance with local health authorities.

(j) Payment and performance bonds in an amount equal to 100% of the guaranteed maximum contract price for the Improvements in the Construction Contract, issued by a bonding company satisfactory to us, with a dual-obligee rider naming us as co-obligee.

(k) An updated list of all subcontractors and suppliers with whom the Contractor has a contract for the construction of any part of the Improvements, prepared and certified by the Contractor.

(l) An agreement of the Contractor assenting to the assignment of the Construction Contract to us and agreeing to perform on our behalf all obligations under the Construction Contract upon any Event of Default.

(m) A certification of the architect preparing the Plans, certifying that the Plans comply with all applicable laws and regulations and granting us the right to retain and use the Plans in completing construction of the Improvements, upon any Event of Default.

(n) You have deposited the Borrower Funds with us.

(o) Evidence satisfactory to us that there is not any pending litigation against you.

(p) Evidence satisfactory to us that no Events of Default shall have occurred.

(q) Evidence satisfactory to us that the Contractor has all required licenses and insurance coverages to perform its obligations under the Construction Contract and that no event of default under the Construction Contract shall have occurred.

(r) Such other conditions as we may reasonably impose and which are set forth in Exhibit E, if any, to this Loan Agreement.

6. Other Terms of Disbursements.

(a) *Interim Disbursements.* All interim disbursements shall be requested by you or the Contractor delivering to us a Draw Request duly executed by you and the Contractor in accordance with the Draw Schedule. At least **five (5)** business days prior to the date on which each draw is to be made, the Draw Request and all other documents, instruments, and writings which may then be required by us shall be delivered to us. The amount of each disbursement shall be based on the value of the work completed (WORK IN PLACE ONLY) and approved by us. The disbursement will be calculated on the work actually completed less the total of all monies previously drawn. The proceeds of each disbursement shall be applied solely to the payment of those items set forth in the Draw Request and approved by us. IF THE PROGRESS OF THE WORK IN PLACE IS NOT CONSISTENT WITH THE DRAW SCHEDULE, WE WILL DISBURSE ONLY THE AMOUNT OF FUNDS THAT WE DETERMINE, IN OUR SOLE AND ABSOLUTE DISCRETION, IS APPROPRIATE BASED ON OUR INSPECTION OF THE PROGRESS OF THE WORK. Any advance that may be made by us prior to the fulfillment by you of any requirements specified by us or of any condition precedent set forth in this Loan Agreement, the Note, the Security Instrument or any of the other documents related to the Loan shall not be deemed a waiver of our right to have such requirement or condition precedent fulfilled prior to making subsequent disbursements.

(b) *Binding Effect of Draw Request.* Presentation of the Draw Request to us by you and/or your acknowledgement of the Draw Request shall constitute your representation to us that all representations and warranties set forth herein and in the Draw Request are true and correct, all work completed through the date of the Draw Request has been fully accepted by you, completed in a good and workmanlike manner, in conformity with the Plans and shall additionally constitute your unconditional waiver of any claims to the effect that such work was not performed in such manner.



LOAN #: 12031809861

(c) *Partial Lien Waivers/Releases.* It shall be a condition of all Interim disbursements that each Draw Request must be accompanied by a release or waiver of liens, satisfactory to us and the Title Company in all respects, signed by each supplier and subcontractor who was to be paid under the prior Draw Request.

(d) *Form of Disbursements.* All interim disbursements may be made directly by us or indirectly through the Title Company or other settlement or escrow agent, as we may determine in our sole discretion, as permitted by law. All disbursements shall be made by check or other appropriate credit transfer to your order or, in our discretion, individually to or jointly with you and the Contractor, or any subcontractor or supplier, if we deem it necessary to avoid a potential mechanic's lien claim. In such circumstance, we may first give you notice of our intention to obtain a release of such claim with such a disbursement. All such payments made by us to persons other than you shall be deemed made for your use and benefit with the same force and effect as if disbursed directly to you.

(e) *Disbursements for Indirect Costs.* Subject to the terms set forth herein, disbursements for indirect costs as described in the Budget (other than for interest, contingencies, Contractor overhead or supervision) shall be made to reimburse you for the amount of the indirect costs relating to the construction of the Improvements previously paid by you pursuant to the approved Budget (as evidenced by invoices and receipts, cancelled checks or other evidence of payment of all such indirect costs, and not merely the amount covered by the disbursement by us), all as approved by us.

(f) *Interest Reserve.* If you, the Borrower, elect to establish an Interest Reserve Account, the Budget will include an interest reserve to cover the estimated interest to be accrued on the outstanding portion of Loan during the Construction Period. We shall make disbursements of the appropriate interest payments to ourselves from the interest reserve account on the dates indicated in the Note without any prior notice to you, provided that there are sufficient funds available. In the event that sufficient funds are no longer available from the interest reserve, you agree to pay interest on the Note to us from funds outside the Loan. You further agree that disbursements on account of accrued interest on the Loan shall become part of the outstanding Loan principal upon disbursement, and interest will accrue thereon under the terms of the Note.

(g) *Multiple Borrower Draw Requests.* If you, the Borrower, are more than one person, then you hereby agree that either or any of them are authorized to approve Draw Requests on your behalf; provided, however, that if we receive conflicting instructions, we shall be under no obligation to make the related disbursement until such time as we receive consistent instructions and authorizations.

(h) *Change Orders.* You will provide to us copies of all change orders for approval. You will not permit the Contractor to do any work not included in the Construction Contract until a written change order has been signed by you and by the Contractor and we have approved it in writing. We may refuse to approve any change that will adversely affect the value of the Property as security for the Loan, or will cause the completion of the Improvements to be delayed beyond the Completion Date, or if you do not have sufficient funds to pay for such change. You agree to pay for all changes approved by us as work is performed or to otherwise satisfy us that such work will be timely paid, and further agree to execute any amendments or modifications of this Loan Agreement considered necessary by us to evidence such changes.

7. Final Disbursement. We shall have no obligation to release any portion of the Loan Proceeds allocated to the final disbursement, as set forth on the Draw Schedule, or the Holdback (if any), or any other undisbursed Loan Proceeds, or to otherwise pay any remaining costs of construction, until all of the following shall have occurred to our satisfaction, or shall have been waived by us:

(a) A written and signed notice from you stating that the Improvements have been completed to your satisfaction and requesting that final disbursement be made and the Holdback (if any) released.

(b) A final site visit and review of the progress of construction by an inspection service selected by us confirming that the improvements have been completed substantially in conformance with the Plans and that a valid notice of completion (or notice of termination or such other notice of similar import) has been filed for the Improvements, if such notice is required by applicable law.

(c) An affidavit from the Contractor that all bills for labor and materials have been paid and that payment of the final draw request to the Contractor will constitute payment in full of all sums payable under the Construction Contract, together with final lien releases or waivers, satisfactory to us and the Title Company in all respects, from the Contractor and from all subcontractors, materialmen and laborers have been received by us.

(d) A certificate of occupancy or equivalent governmental approval has been obtained and provided to us.

(e) An as-built update of the survey of the Property satisfactory to us and the Title Company in all respects.



LOAN #: 12031809861

(f) The Title Company shall have issued a new title insurance policy, or an endorsement to our existing title insurance policy respecting the Property, insuring that the Security Instrument is a first lien on the Property, not subject to any mechanics' or contractor's liens or mortgage rights, and subject only to those other matters set forth as exceptions in our original title insurance policy and approved by us or those consented to by us thereafter; and, you agree to deliver an indemnity agreement respecting lien claims to the Title Company if required to enable it to issue any such endorsements or title insurance policy.

(g) If a Builder/All Risk Policy was obtained at or before closing it must be replaced with a homeowner's extended coverage hazard insurance policy in your name from an insurer and in the amount and with such coverage as we deem satisfactory naming us as loss payee or mortgagee. If the Property is located in a federally designated flood plain and flood insurance was not required prior to closing, a flood insurance policy from an insurer and in the amount and form acceptable to Lender must also be delivered to Lender. You must also provide evidence that Borrower has paid for **twelve (12)** months coverage under all such policies.

(h) Evidence of payment of real estate taxes on the Property and delivery of escrow deposits for taxes, hazard and/or flood insurance or other assessments required by us.

(i) Payment in full of any interest accrued during the Construction Period.

(j) The appraisal of the Property provided Lender as a condition for closing the Loan has been updated and re-approved by Lender.

(k) All requirements for the final disbursement set forth in Exhibit E, if any, have been satisfied.

(l) Compliance with any other reasonable requirement we request.

8. Lender's Right of Refusal. We shall have no obligation to make any disbursement if at the time the request for such disbursement is made:

(a) You are in default with respect to any provision of this Loan Agreement or any other agreement, instrument, document or writing related to the Loan;

(b) We determine that there are insufficient undisbursed funds to complete the Improvements in accordance with the Plans or the Construction Contract. We may elect to make such disbursement upon the deposit with us by you of additional Borrower equity funds deemed sufficient by us, when added to remaining funds to so complete the Improvements. Any funds so deposited by you shall be drawn prior to any additional disbursements by us;

(c) We determine that construction of the Improvements have not been performed in accordance with the provisions of the Plans or the Construction Contract;

(d) A period of less than **N/A** days has elapsed since the date the previous request for disbursement was made;

(e) Any endorsement increasing coverage of the title policy or update to title in connection with such disbursement indicated any changes in the state of title other than the recording of the Security Instrument, the financing statement filed in connection herewith or any other documents recorded by us or at our direction in connection with the Loan; provided, however, we may make such a disbursement upon the resolution by you of such change in a manner acceptable to us; or

(f) We, in our reasonable estimation, determine from information obtained from any source, that you will be unable to complete the Improvements in accordance with the Plans or the Construction Contract, as well as this Loan Agreement, by the Completion Date.

9. Limitations on Lender's Obligations.

(a) We shall have no obligation, either express or implied, to you, to the Contractor or to any third parties, to verify that advances made pursuant to this Loan Agreement are actually used to pay for labor or materials furnished in connection with the construction of the Improvements. You agree to assume all risks in the event the Contractor fails to pay for any labor or material so furnished.

(b) We shall have no liability or obligation, either express or implied, to you, to the Contractor, or to any third parties, in connection with the Improvements, their construction, or improvement except to advance monies as provided under this Loan Agreement. Further, we are not liable for the performance of the Contractor



or any other third parties for any failure to construct, complete, protect, or insure the Improvements or the Property. Nothing under this Loan Agreement shall be construed as a representation or warranty, express or implied, on our part.

10. Right of Lender to Inspect. We shall have the right, but not the obligation, to inspect the Property and the Improvements from time to time. You agree to provide proper facilities for making such inspections by such inspector or inspectors as we may appoint; provided, however, that we shall not be obligated to make any such inspections and, if such inspections are made, we shall have no responsibility or liability for the failure or default of the Contractor or any subcontractor, material supplier, or laborer to construct the Improvements in accordance with the Construction Contract or Plans; for the payment of any cost or expense incurred in connection with such construction; or for the performance or non-performance of any obligation of the Contractor or you to any person furnishing labor or materials in connection with such construction, it being agreed that neither you, the Contractor, nor any person having an interest in the Property or the Improvements shall have a right to rely on the procedures employed by us, such procedures being employed solely for our benefit. Further, our agreement to advance funds under this Loan Agreement is expressly conditioned upon our right to inspect the Property and the Improvements and to determine compliance with this Loan Agreement; provided however, that our inspection of the same and determination to advance funds under the provisions of this Loan Agreement shall not be, and may not be deemed to be, a warranty or representation as to the quality, serviceability, habitability, or merchantability of the construction of the Improvements or any portion thereof, it being understood and agreed by you that any inspections made during the course of construction by us or on our behalf, including the review and approval of the Plans, are solely for our benefit; and we will not in any way be responsible for the construction of the Improvements or their sufficiency or quality. Without limitation on the foregoing, the estimated expense of such inspections shall be provided for in the Budget and paid for by you. In the event we determine that additional inspections are required, or additional inspections are performed at your request, the cost of such additional inspections shall be paid by you.

11. Delayed Completion.

(a) The construction of the Improvements and all conditions for the final disbursement of the Loan Proceeds must be fully completed to our satisfaction by no later than the Completion Date. If all the work has not been completed, or any conditions for the final disbursement of the Loan Proceeds have not been satisfied and accepted by us by the Completion Date, we shall have the right to exercise either of the following remedies, as we shall choose in our sole and absolute discretion:

- declare an Event of Default and exercise all of the rights reserved to us in the Loan Documents to act in case of an Event of Default, including without limitation acceleration of the Loan balance and foreclosure; or
- extend the time for construction, in which case you agree to pay the costs, fees and expenses associated with such extension, including Project Delay Surcharges (as hereinafter described), extension fees, document preparation fees, courier fees, recording fees, title insurance costs, and all other costs incurred or required to effectuate an extension of the Construction Period.

(b) You understand and agree that we shall have no obligation to permit more time for construction. The time you select for the completion of the Improvements is up to you, and failure to fully complete all construction and meet all required conditions within the time you choose shall be an Event of Default. Any extension that is agreed to by us shall be at our sole discretion.

(c) To the extent permitted by law, in order to offset the costs incurred by us when the completion of construction is delayed, or when the materials and documents necessary to document the same are not received by the Completion Date, you agree that, in addition to any other charges and costs, in the event that we shall extend the Construction Period, you shall pay us a Project Delay Surcharge, for each month that such delay continues or any part thereof. The "Project Delay Surcharge" will be N/A per month on the entire amount of the Loan, including any portion of the Loan Proceeds which has not yet been disbursed other than undisbursed funds in the interest reserve account described in Section 6(f) above. We may directly withdraw the Project Delay Surcharge from any funds on hand, or we may bill you for such sums as shall be necessary to assure completion of the Improvements and the full performance of your obligations, including such sums as shall be needed to cover the Project Delay Surcharge.

12. Right of Lender to Complete. Upon any Event of Default hereunder or a default under any other agreement relating to the Loan, we shall have the right in our sole discretion to enter and take possession of the Property, whether in person, by agent or by court appointed receiver, and to take any and all actions which we in our sole discretion may consider necessary or appropriate to complete construction of the Improvements, including making changes in plans, specifications, work or materials and entering into, modifying or terminating any contractual arrangements, all subject to our right at any time to discontinue



LOAN #: 12031809861

any work without liability. In addition, with or without taking possession of the Property, we shall have the right but not the obligation to complete the Improvements or to cure any of your defaults under any of the Plans. Provided, however, that in so doing so, we shall not assume any liability to you or any other person for completing the Improvements, or for the manner or quality of their construction, or for curing any defaults under the Plans; and, you expressly waive any such liability. If we exercise any of the rights or remedies provided in this paragraph, that exercise shall not make us, or cause us to be deemed to be, your partner or joint-venturer. We in our sole discretion may choose to complete construction in our own name. All sums which are expended by us in completing construction or curing your defaults shall be considered to have been disbursed to you hereunder; such sums shall bear interest at the rate interest is accruing under the Note; and such sums and the interest thereon shall be secured by the Security Instrument. For these purposes, we, in our sole discretion, may reallocate any line item or cost category of the Budget and may make use of any available Loan Proceeds and any sums in the Borrower Funds and the disbursement account. Nothing contained herein shall be construed to make us a mortgagee in possession or to be a waiver or modification of our right to enforce payment of any sums owing to us under the Note, the Security Instrument or this Loan Agreement or to affect our right to foreclose the Security Instrument.

13. Damage to the Improvements. If the Improvements or any part thereof are damaged or destroyed by flood, earthquake, wind, fire, or by other means, you shall restore the Improvements promptly to their condition prior to such damage or destruction and provide whatever funds are necessary (that is, in addition to proceeds of insurance) to complete restoration. All insurance proceeds attributable to such damage or destruction shall be deposited with us or a depository institution designated by us. You understand and acknowledge that, after any such damage or destruction, we shall be under no obligation to continue disbursing Loan Proceeds or insurance proceeds or other funds until the following shall have occurred: (a) if required by us, you shall have provided to us for our approval a revised Budget, revised Plans and any appropriate amendments to the Construction Contract which address such rebuilding; and (b) you shall have deposited with us such additional Borrower Funds as we, in our sole judgment, deem appropriate to assure completion of the Improvements in accordance with any such approved revised Budget and Plans.

14. Power of Attorney. You hereby constitute and appoint us as your true and lawful attorney-in-fact with full power of substitution to complete, or cause to be completed, the Improvements in your name including the right to cause to be advanced any balance which may be held in escrow and any funds which may remain un-disbursed hereunder for the purpose of completing the Improvements in the manner called for by the Plans; to make such additions and changes and corrections in the Plans, which shall be necessary or desirable to complete the Improvements in substantially the manner contemplated by the Plans; to employ such general contractors, subcontractors, agents, architects and inspectors as shall be required for said purpose; to pay, settle or compromise any liens or claims filed or threatened against said Property, or which may be necessary or desirable for the completion of the work or the clearance of title; to execute all applications and certificates in your name which may be required by any construction contract; and, to do any and every act with respect to the construction of the Improvements which you may do in your own behalf. It is understood and agreed that this power of attorney shall be deemed to be a power coupled with an interest that shall not be affected by the subsequent death, disability or incapacity of the Borrower and shall be irrevocable. We, as attorney-in-fact, shall also have the power to prosecute and defend all actions or proceedings in connection with the construction of the Improvements and to take such action and require such performance as is deemed necessary. You hereby assign and quitclaim to us all sums to be drawn hereunder and all sums in escrow conditioned upon the use of said sums, if any, for the completion of the Improvements.

15. Subrogation. It is understood and agreed that the funds advanced by us hereunder, to the extent that such funds are utilized to pay, discharge, or release in whole or in part any outstanding liens and charges against the Property, have been advanced by us at the request of you and the Contractor and upon the representations by you and the Contractor that such funds are due and are secured by valid and enforceable liens against the Property. We shall be subrogated to any and all rights, superior titles, liens, and equities owned or claimed by any owner or holder of any such outstanding liens, charges and indebtedness which are paid by us or which are acquired by us by assignment or releases by the holder thereof upon payment.

16. Taxes and Insurance. It is agreed that we shall escrow or impound for taxes and insurance during the loan construction phase; provided, however, subsequent to the Construction Period during the term of the Loan, we may require that an escrow be established to provide for monthly deposits, and any initial deposit as we may determine, in our sole discretion, to cover payment of estimated annual taxes, insurance premiums, municipal assessments and private mortgage insurance, if any. You shall keep the Property and the Improvements insured as provided in this Loan Agreement and shall timely pay all taxes and other amounts that may be due and owing on the Property. We have the option, but not the obligation, without demand or notice and without waiver of any right whatever, to:



LOAN #: 12031809861

(a) Pay or discharge any lien or claims upon the Property or the Improvements or pay any delinquent tax or assessment thereon; and, upon such payment, we shall be subrogated respectively to the rights of the holder of such lien or claim or to the right of the taxing authority; and

(b) Advance any unpaid insurance premiums and obtain and maintain any insurance policy required by this Loan Agreement, but not provided by you.

You hereby expressly agree to repay to us, upon demand, any and all advances made under this Loan Agreement to cure any default or Event of Default, together with interest thereon at the rate specified in the Note from the respective dates of such advances until paid, and that all such advances shall become a part of the Loan under the Note secured by the Security Instrument.

17. Borrower's Representations, Covenants and Warranties. You hereby further warrant, covenant, agree and represent, which warranties, covenants, agreements, and representations shall be deemed to be made with each Draw Request hereunder and shall survive the making of any and all Draw Requests, as follows:

(a) That all obligations shall be performed by you under the Construction Contract, the Note, the Security Instrument, this Loan Agreement and any instrument, document, or writing referenced herein or related to the Loan; and you shall promptly pay when due, from the Loan Proceeds or from your separate funds in the event of any change order or variance with the Plans, all costs, charges, and expenses incurred in connection with the construction of the Improvements;

(b) THAT NO LABOR HAS BEEN PERFORMED OR FURNISHED AND NO MATERIALS HAVE BEEN DELIVERED TO THE PROPERTY AND THAT NO LABOR WILL BE PERFORMED OR FURNISHED AND NO MATERIALS WILL BE DELIVERED PRIOR TO THE RECORDING OF THE SECURITY INSTRUMENT;

(c) That there are no pending lawsuits or judgments against you that may in any way impair your ability to fully perform all agreements contained in this Loan Agreement and any other agreement relating to the Loan;

(d) That the Property will be kept free and clear of any and all liens other than our security interest and any financing statements or other documents filed by us in connection herewith, and you will protect the Property and the Improvements from events and circumstances that cause or may cause the same to decrease in value;

(e) That the Improvements shall remain vacant until completion so as not to impair any insurance policy described under this Loan Agreement;

(f) That the Construction Contract and the Plans constitute the entire agreement between you and the Contractor in connection with the construction of the Improvements, and that no material change in the Construction Contract or the Plans shall be binding upon us unless approved by us in writing;

(g) That you and the Contractor have paid, or will pay, contemporaneously with each disbursement, for all labor or materials furnished in connection with the construction of the Improvements and shall submit to Lender all such receipts, affidavits, canceled checks, lien releases or other evidence of payment of all debts connected with the Improvements as may be requested by Lender from time to time;

(h) That all work performed up to the date of each disbursement has been performed in a good and workmanlike manner pursuant to the provisions of the Construction Contract and this Loan Agreement and in conformance with the Plans;

(i) That all construction has been performed in strict compliance with all applicable ordinances, statutes, regulations, and subdivision requirements or restrictions, which affect the Property;

(j) That no Event of Default exists under this Loan Agreement, or any other documents related to the Loan, and that no event has occurred that with the giving of notice, lapse of time or otherwise, would constitute an Event of Default under this Loan Agreement or any other documents related to the Loan;

(k) That all material delivered to and upon the Property for the purpose of being incorporated in the Improvements shall be considered annexed to the Property and become a part thereof, and shall be subject, as against you, to our rights under this Loan Agreement and Security Instrument;

(l) That within thirty (30) days of the date of recordation of the Security Instrument, you shall commence construction of the Improvements, that the Improvements shall be completed substantially in accordance



LOAN #: 12031809861

with the Plans, the Construction Contract and this Loan Agreement with only such changes as may be approved in writing by us, and that the construction of the Improvements shall be completed on or before the Completion Date;

(m) That the monies to be advanced under this Loan Agreement, together with other funds now available to you, are sufficient to fully construct the Improvements and pay all expenses necessary for such construction;

(n) That each disbursement made under this Loan Agreement shall be used solely for the payment of and for materials, labor, services, costs, and expenses provided for or incurred in connection with the construction of the Improvements or for such other costs and expenses agreed to by us in writing;

(o) That you will immediately notify us and, within 24 hours of receipt, provide us with copies of any claim, notice of intent to file a mechanics lien or the like that you may receive from any subcontractor or supplier performing work or providing materials in connection with the construction of the Improvements; and

(p) That you have not and will not enter into a community property agreement, community property trust or other trust without lender's prior written consent.

18. Environmental Concerns. You warrant and represent that the Property is not now being used and to the best of your knowledge has not been used in violation of any federal, state or local environmental law, ordinance, or regulation; that you have not filed or been required to file any federal, state or local report of hazardous substances found or disposed on the Property; that no proceeding has been commenced or notice received concerning any alleged violation of any environmental law, ordinance or regulation; that to the best of your knowledge the Property is free of underground storage tanks, out-of-use transformers, hazardous, radioactive or toxic wastes, contaminants, oil or other similar materials; that the Property has not been and shall not be used in conjunction with or for any activity involving, directly or indirectly, the generation, treatment, storage, transportation, manufacture, use or disposition of hazardous or toxic chemicals, materials, substances or waste of any kind; neither the Property, the soil making up any portion thereof, nor the ground water thereunder making up any portion thereof shall be contaminated so as to be subject to any "clean-up" or similar requirement under any applicable rule, requirement, regulation, ordinance, or law or governmental authority that would in any way inhibit, impair, delay or increase the cost of the Improvements or use of the Property; and that you shall not install or allow to remain upon the Property any chemical, material or substance, exposure to which is prohibited, limited, or regulated by any federal, state, county, regional or local authority, or which, even if not so regulated, may or could pose a hazard to the health and safety of the occupants of the Property, to the owners of the property adjacent to the Property, or any person. You hereby (i) release and waive any future claims against us for indemnity or contribution in the event you become liable for cleanup or other costs under any such environmental laws, and (ii) agree to indemnify and hold us harmless against any and all claims, losses, liabilities, damages, penalties, and expenses which we may directly or indirectly sustain or suffer resulting from a breach of this Section 18 or as a consequence of any use, generation, manufacture, storage, disposal, release or threatened release occurring prior to your ownership or interest in the Property, whether or not the same was or should have been known to you. The provisions of this Section 18, including the obligation to indemnify, shall survive the payment of the Note and shall not be affected by our acquisition of any interest in the Property, whether by foreclosure or otherwise.

19. Lender's Costs. To the extent permitted by applicable law, we shall be reimbursed by you for all expenses of any kind, including without limitation attorney's fees, that may be incurred by us in connection with or arising out of this Loan Agreement, and we may deduct from any disbursement or advance to be made hereunder any amount necessary for the payment of any unpaid interest owing to us, any fees, expenses, charges, liens, or encumbrances relating to the construction of the Improvements or upon the Property, or any other amounts necessary for the payment of the cost of constructing the Improvements, and all such deductions may be applied to the payment of such sums, in which case said deductions shall be deemed to be advances under this Loan Agreement.

20. Borrower's Indemnification. WITHOUT LIMITING ANY OTHER LIMITATION ON LENDER LIABILITY SET FORTH HEREIN, YOU HEREBY AGREE THAT YOU SHALL INDEMNIFY, DEFEND AND HOLD US AND OUR DIRECTORS, OFFICERS, EMPLOYEES, AGENTS AND AFFILIATES ("INDEMNIFIED PARTIES") HARMLESS FOR, FROM AND AGAINST ANY AND ALL ACTIONS, CLAIMS, DEMANDS, DAMAGES, COSTS, EXPENSES, AND OTHER LIABILITIES, INCLUDING WITHOUT LIMITATION ATTORNEY'S FEES, INCURRED OR ALLEGED AGAINST THE INDEMNIFIED PARTIES ARISING OUT OF OR IN ANY WAY RELATED TO THE PROPERTY, THIS CONSTRUCTION LOAN AGREEMENT AND/OR THE CONSTRUCTION OF THE IMPROVEMENTS. The provisions of this Section 20 shall survive the termination of this Loan Agreement and the repayment of the Loan.



LOAN #: 12031809861

21. Events of Default. In addition to the terms of the Note, the Security Instrument or any other agreement relating to the Loan, the occurrence of any of the events described in this Section 21 (each an "Event of Default" and collectively, the "Events of Default") shall permit us, at our option, to declare the Note in default and, after such notice and opportunity to cure as is afforded to you under the Loan Documents, to exercise such remedies available to us under the Loan Documents as we may elect. The Events of Default shall include:

(a) Any default by you in making any payment or deposit as and when required hereunder or under the Note, the Security Instrument or other Loan Documents;

(b) Any representation or warranty made by you herein, in the Note, the Security Instrument or other Loan Documents, or in any other document provided hereunder or otherwise in connection with the Loan, proves to have been false or misleading in any material respect when made;

(c) We fail to have a legal, valid, binding, and enforceable first lien on the Property for the full amount of the Loan;

(d) Work is discontinued on the Improvements for a period of **thirty (30)** days and we have not excused such discontinuance or, if we have excused the discontinuance, work is not commenced and completed within the period specified by us;

(e) If the construction of the Improvements is not performed in a good and workmanlike manner or fails to continue to meet the requirements of all applicable federal, state, county, municipal or other government regulations, including, without limitation, those relating to zoning, building codes and valid permitting;

(f) If a claim by a potential lien claimant is filed pursuant to applicable law, or, if applicable, a 'stop notice' or 'withhold notice' is served on us pursuant to applicable law, and you have not taken the steps necessary to protect us against the effects of such action;

(g) You default in the Construction Contract performing any other obligation contained in this Loan Agreement, the Note, the Security Instrument or other Loan Documents, or in any document issued under or provided for herein or which otherwise relates to the Loan, which default is not cured in the time period (if any) set forth in the applicable document; and

(h) You make an assignment for the benefit of creditors, apply for the appointment of a trustee or receiver, or commence any proceedings under any bankruptcy, insolvency, reorganization, debt adjustment or similar law of the United States or any jurisdiction, or if an involuntary petition or action under any of the foregoing is filed against you.

22. General Provisions.

(a) *No Waiver.* Failure or delay by us to exercise or enforce any right, power, or remedy under this Loan Agreement shall not constitute a waiver of such right, power or remedy under the same.

(b) *Priority Of This Agreement.* During the term of the construction of the Improvements, the provisions of this Loan Agreement shall control in the event there are any conflicts with any provisions of any instrument, documents, or writing referenced herein. After construction is completed, the terms of the Note and Security Instrument shall govern.

(c) *Survival.* Any representation or warranty made herein by you shall survive the termination of this Loan Agreement and the repayment of the Loan.

(d) *Notices.* Any notice, Draw Request or other communication required or permitted to be given under this Loan Agreement shall be in writing and shall be sent to the address indicated above for each respective party as follows: (i) by hand delivery, (ii) by overnight mail with delivery confirmation, (iii) by certified or registered first class mail with return receipt requested, or (iv) by use of confirmed electronic facsimile transmission with a copy of such transmission delivered by mail or hand delivery.

(e) *Assignment.* You may not assign your rights nor delegate your obligations under this Loan Agreement, the Note and Security Instrument, without our prior written consent, which, unless otherwise provided in the relevant agreement, may be withheld in our sole and absolute discretion. We may assign all of our rights and obligations under this Loan Agreement, including the obligation to make disbursements of the Loan Proceeds under this Loan Agreement, without your consent.



(f) *Binding Effect.* This Loan Agreement shall inure to and bind the heirs, devisees, legal representatives, successors and permitted assigns of the parties hereto.

(g) *Lender's Rights Cumulative.* All rights, powers, and remedies of the Lender contained in this Loan Agreement are cumulative and in addition to all other rights, powers, and remedies created in any other document relating to the Loan or existing under the law.

(h) *Severability.* If any one or more of the provisions of this Loan Agreement, or the applicability of any such provision to a specific situation, shall be held invalid or unenforceable, such provision shall be modified to the minimum extent necessary to make it or its application valid and enforceable, and the validity and enforceability of all other provisions of this Loan Agreement and all other applications of any such provision shall not be affected thereby.

(i) *Headings.* The headings contained in this Loan Agreement are for reference purposes only and shall not in any way affect the meanings or interpretations hereof.

(j) *Governing Law.* This Loan Agreement shall be governed by laws of the State where the Property is located without regard to principles of conflict of laws.

(k) *Limitation on Beneficiaries.* This Agreement is made by you for our sole benefit; and no other person shall be deemed to have any privity of contract hereunder, nor any right of action hereon. Without limiting the generality of the foregoing, any disbursement that may be made by us hereunder directly to the Contractor or any subcontractor or supplier shall not be deemed a recognition by us of a third party beneficiary status of any such party or entity.

(l) *Conflicts With Construction Contract.* You expressly covenant and agree that, if any terms and requirements of this Loan Agreement are inconsistent in any way with provisions in the Construction Contract, the Construction Contract will be modified and/or interpreted to conform to and give effect to the requirements of this Loan Agreement.

(m) *Further Assurances.* You agree that, from time to time, you will sign and deliver to us any document and assurances we may require to maintain the priority of our security interest in the Property and the Improvements and to help us complete construction of the Improvements if you should be in default.

(n) *Exhibits.* All exhibits referred to herein and attached hereto are incorporated herein and made a part hereof as if fully set forth herein.

(o) *Extension of Authority.* We may designate agents or independent contractors to exercise any of our rights hereunder; and, any reference herein to us shall be deemed to include our employees, agents and independent contractors.

(p) *Time.* Time is of the essence of this Loan Agreement.

(q) *Joint & Several Obligations.* If the Borrower is more than one person, the obligations and undertakings of the Borrower herein shall be deemed to be the joint and several obligations and undertakings of all persons comprising the Borrower.

(r) *No Special Relationship.* The relationship between Lender and Borrower is solely that of lender and borrower. Lender has no fiduciary or other special relationship with or duty to Borrower and none is created by the Loan Documents. Nothing contained in the Loan Documents, and no action taken or omitted pursuant to the Loan Documents, is intended or shall be construed to create any partnership, joint venture, association, or special relationship between Borrower and Lender or in any way make Lender a co-principal with Borrower with reference to the Property, the improvements or otherwise. In no event shall Lender's rights and interests under the Loan Documents be construed to give Lender the right to control, or be deemed to indicate that Lender is in control of, the business, properties, management or operations of Borrower.

(s) Notwithstanding anything to the contrary, in no event shall interest charged under this Loan Agreement exceed the maximum rate allowed by applicable law.

(t) *Entire Agreement.* This Loan Agreement and the other Loan Documents represent the final agreement between the parties and may not be contradicted by evidence of prior, contemporaneous or subsequent oral agreements of the parties, and may be amended only by contemporaneous or subsequent written agreement signed by both parties.



LOAN #: 12031809861

You acknowledge that you have read and fully understand all terms and conditions of this Loan Agreement.

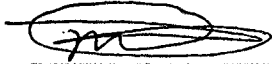

(Seal)

MICHAEL Q. WALCH

State of Utah
County of Savis

This instrument was acknowledged before me on JULY 29, 2019 (date) by MICHAEL Q. WALCH (name(s) of person(s)).

(Seal, if any)

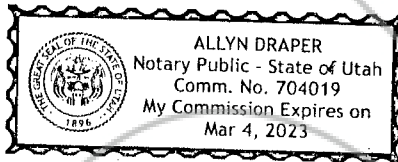

Allyn Draper
(Signature of notarial officer)

Title (and rank): Notary Public



LOAN #: 12031809861

RESIDENTIAL CONSTRUCTION LOAN AGREEMENT

Exhibit A

"Description of Property"

**THIS PAGE IS A PLACEHOLDER:
Please replace with the necessary attachments.**

Multistate – Residential Construction Loan Agreement (Construction/Permanent Loan)
Ellie Mae, Inc.

GCNSTPAGR 0317
GCNSTPAGL (CLS)





EXHIBIT 'A'

PARCEL 1:

PARCEL 5 OF THE BRADLEY AND LEANN WALCH PARCEL MAP LOCATED IN THE SECTION 5, TOWNSHIP 7 SOUTH, RANGE 61 EAST., RECORDED APRIL 24, 2018 AS DOCUMENT NO. 2018-154132 IN LINCOLN COUNTY.

PARCEL 2:

A NON-EXCLUSIVE EASEMENT FOR INGRESS AND EGRESS AS SHOWN ON THE PARCEL MAP RECORDED JULY 30, 1996 AS INSTRUMENT NO. 105519, IN BOOK A OF MAPS, PAGE 491 IN THE OFFICE OF THE LINCOLN COUNTY RECORDER.

PARCEL 3:

A NON-EXCLUSIVE EASEMENT FOR INGRESS AND EGRESS AS SHOWN ON THE PARCEL MAP RECORDED October 20, 2004 AS INSTRUMENT NO. 123238 IN BOOK C OF MAPS, PAGE 80 IN THE OFFICE OF THE LINCOLN COUNTY RECORDER.

PARCEL 4:

A NON-EXCLUSIVE EASEMENT FOR INGRESS AND EGRESS AS SHOWN ON THE PARCEL MAP RECORDED MAY 12, 2006 AS INSTRUMENT NO. 125608, BOOK C OF MAPS, PAGE 202 IN THE OFFICE OF THE LINCOLN COUNTY RECORDER.

PARCEL 5:

A NON-EXCLUSIVE EASEMENT FOR INGRESS AND EGRESS AS SHOWN ON THE PARCEL MAP RECORDED APRIL 24, 2018 AS INSTRUMENT NO. 2018-154132 IN THE OFFICE OF THE LINCOLN COUNTY RECORDER.

LOAN #: 12031809861

RESIDENTIAL CONSTRUCTION LOAN AGREEMENT

Exhibit B

"Construction Budget"

**THIS PAGE IS A PLACEHOLDER:
Please replace with the necessary attachments.**

Multistate – Residential Construction Loan Agreement (Construction/Permanent Loan)
Ellie Mae, Inc.

GCNSTPAGR 0317
GCNSTPAGL (CLS)



CONTRACTORS DETAILED CONSTRUCTION BUDGET FORM

9-00000000

Please have the Contractor complete the Contractors Detailed Construction Budget Form. This will be used to perform Land Gorilla's Project Review for your proposed home. Please account for any prepaid items in the appropriate column and provide comments if necessary. This form will be used to administer construction funds on a line item basis.

BORROWER Quinn & Chrisanne Walch

CONTRACTOR Muddy River Contractors, Inc.

Lot Size: 1.89 Acres

ADDRESS Lamb Blvd

GLA in square feet: 2544 SF

CITY / STATE / ZIP Alamo, NV 89001

Basement square feet: 891 SF

APN# 004-141-75

ITEM NUMBER	DESCRIPTION	COST	PRE-PAID	SCHEDULED VALUE	COMMENTS
SOFT COSTS					
200	Architect / Plans	\$ 2,079.50	\$ 2,079.50		America's Best House Plans Order #17110211232
203	Permits/ hook up fees	\$ 2,500.00	\$ 615.44		Alamo S&W Inv. 30398 / Lincoln Co. Chk#64717
204	Impact fees	\$ 5,500.00			
205	Contractors Profit	\$ 15,000.00			
207	Contractors Supervision	\$ 3,000.00			
208	Soils Report				
209	Builders Risk Insurance	\$500			
210	Survey	\$ 880.00	\$ 880.00		Lenard Smith Land Survey inv. 342
211	Termite Inspection				
212	Contractors Overhead				
213					
MISC	Interest Reserve				
MISC	Construction Costs				
MISC	Contingency				
	Total Soft Costs	\$ 29,459.50	\$ 3,574.94		
	Hard Costs				
301	General Conditions	\$ 4,540.50			

702	Tile, Floor Covering				Inc
703	Hardwood Flooring				Inc
704	Linoleum / Vinyl Flooring				Inc
705	Misc. Floor Covering				Inc
706	Gutters & Downspouts	\$	1,000.00		
707	Appliances	\$	2,250.00		
708	Door Hardware	\$	900.00		
709	Garage Door(s)	\$	2,500.00		
710	Shower Doors / Mirrors / Hardware	\$	600.00		
711	Interior Trim				
712	Central Vac				
713	Alarm				
714	Light Fixtures Interior / Exterior	\$	2,000.00		
715	Water Softner				
716	Accessories				
717	Hardware - Finish				
718	Solar				
719	Closet Finish				
801	Driveway & Walkways	\$	400.00		
802	Patio	\$	660.00		
803	Decks				
804	Landscaping				
805	Fencing				
806	Barn				
807	Outerbuilding / Carport				
808	Theater				
809	Pool				
810	Public Sidewalks & Curbs				
811	Cleanup & Dumpsters	\$	927.00		

Land				
Cash at closing				
Total Hard Costs	\$	304,577.50	\$	7,149.88
Total Soft and Hard Costs	\$	334,037.00		
Total Construction Loan	\$	349,200.00		

The Contractor acknowledge that the above itemized costs represent the total funds needed to complete construction of the project. It is further acknowledged that the lender will not disburse line item funds that exceed those described above in the Scheduled Value column.

[Handwritten Signature]

BUILDER / CONTRACTOR SIGNATURE

6-25-19

DATE

[Handwritten Signature]

BORROWER SIGNATURE

05/14/19

DATE

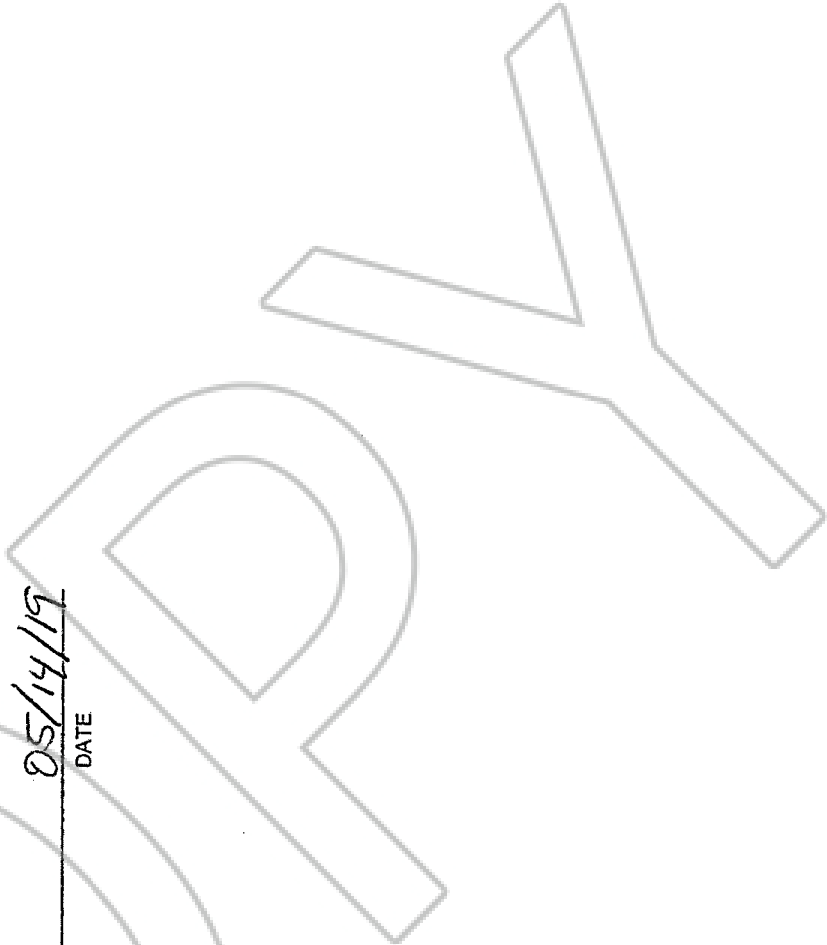

LOAN #: 12031809861

RESIDENTIAL CONSTRUCTION LOAN AGREEMENT

Exhibit C

"Draw Request and Disbursement Authorization"

**THIS PAGE IS A PLACEHOLDER:
Please replace with the necessary attachments.**

Multistate - Residential Construction Loan Agreement (Construction/Permanent Loan)
Ellie Mae, Inc.

GCNSTPAGR 0317
GCNSTPAQL (CLS)



DRAW REQUEST FORM

Form ID 34112

Each draw request must be accompanied by supporting documentation, completed forms and all State required filings. Upon receiving a completed draw request package, the Construction Loan Administrator (CLA) will review the submission for completeness, order an inspection of the property and review title. If any issues arise during the draw request process the CLA will contact the submitter to resolve the issue. The CLA will communicate draw and funding expectations at time of draw submission. Typical draw processing time varies from 3-5 business days. The Construction Loan Administrator will provide more detail on the Lender's cut-off times for next day fundings. Turn-times vary depending on the Lender's payment method, policies and procedures.

LOAN FILE # _____ DATE 6-28-19 DRAW # 1

BORROWER LAST NAME Wachs

PROPERTY ADDRESS 170 Lamb Blvd

Alamo, NV 89001

PROJECT CONTACT FOR INSPECTION _____

PROJECT CONTACT PHONE NUMBER _____

PROJECT CONTACT EMAIL _____

Budget Line Item	Description (as listed on budget)	Amount Requested	Payee Name (to be paid)	Payee Address
203	Permits / Hookup Fees (Bal.)	\$ 1984.56	Muddy River Contractors	
204	Impact Fees	\$ 5,500.00	"	
209	Bldg Risk Premium	\$ 500.00	"	
405	1/2 Down Trusses	\$ 8,000.00	"	
412	1/2 Down Windows	\$ 3,250.00	"	
605	1/2 Down Kitchen Cabinets	\$ 2,600.00	"	
607	1/2 Down Bath cab	\$ 800.00	"	
Total		\$ 22,534.56		

By signing below, the Borrower and Builder/Contractor represent and agree that both parties have reviewed the Plans. The Plans are satisfactory and have been approved by all governmental authorities having jurisdiction over the Property and the Work. The Improvements do not violate any of the conditions, covenants or restrictions on the Property. There are no defaults under the terms of the Construction Loan Agreement, any other Loan Document, or under the Construction Contract. The Work for which this Request is made has been duly completed in a good and workmanlike manner, in accordance with the Plans and in compliance with all governmental regulations. The Loan Commitment Amount remaining will be sufficient to complete all improvements contemplated by the Construction Loan Agreement, the Plans and the Construction Contract. Lender and/or Lender's authorized agent has received invoices, work order changes and construction lien waiver(s) from the Builder/Contractor for all Work covered by this Request, and for all Requisitions previously submitted. The funds obtained with the request for advance will be used to pay in full the costs of labor performed, materials supplied and/or sub-Builder/Contractor invoices as requested in this Request. There has been NO material adverse change in Borrower's financial condition or employment status since the time Borrower applied for the Loan(s). By signing below Borrower and Builder/Contractor request Lender to pay the above payee(s).

Borrower and Builder/Contractor Hereby Authorize the Lender and Disbursement Agent to pay directly to the Builder/Contractor the amount of this request, and the Borrower and Builder/Contractor unconditionally release the Lender from any liability related to this request and agree to indemnify it against any claims, expenses and/or losses that may be related or asserted by any Third Party alleging that it has not been paid by the Builder/Contractor for any work.

Clarence Lewis Muddy River Contractors

Check Payable to the Builder / Contractor	Wire to the Builder / Contractor
	Bank Name: <u>America First Credit Union</u>
	ABA Routing #: <u>324377516</u>
	Account Name: <u>Muddy River Contractors, LLC</u>
	Account #: <u>7581747</u>

Borrower and Builder/Contractor hereby authorize the Lender and the Disbursement Agent to pay directly to the Borrower the amount of this request. The Borrower and Builder/Contractor unconditionally release the Lender from any liability related to this request and agree to indemnify it against any claims, expenses and/or losses that may be related thereto, asserted by the Builder/Contractor alleging that it has not been paid by the Borrower for any work, or asserted by any Third Party alleging that it has not been paid by the Builder/Contractor for any work.

Check Payable to the Borrower	Wire to the Borrower
	Bank Name:
	ABA Routing #:
	Account Name:
	Account #:

While the Lender may approve the advance requested herein, it does so only to the extent permitted by applicable law, and makes no warranty or representation as to the quality of work completed and/or material delivered thus far.

Borrower Signature: _____ Date: _____

Builder / Contractor Signature: Glenn Lewis
Muddy River Contractors, LLC

Date: 6-28-19

LOAN #: 12031809861

RESIDENTIAL CONSTRUCTION LOAN AGREEMENT

Exhibit D

"Draw Schedule"

**THIS PAGE IS A PLACEHOLDER:
Please replace with the necessary attachments.**

Multistate – Residential Construction Loan Agreement (Construction/Permanent Loan)
Ellie Mae, Inc.

GCNSTPAGR 0317
GCNSTPAGL (CLS)



CONTRACTOR ACKNOWLEDGEMENT

PROPERTY ADDRESS: Lamb Blvd. Alamo, NV 89001

BORROWER NAME: Michael Quinn Walch

BORROWER MAILING ADDRESS: PO Box 396 Alamo, NV 89001

CO-BORROWER NAME: N/A

CONTRACTOR: Muddy River Contractors, LLC

CONTRACTOR MAILING ADDRESS: PO Box 930 Overton, NV 89040

CONTRACT PRICE \$ 334,037.00 - USD

LENDER LOAN NUMBER: 12031809861

LENDER: Synergy Once Lending, Inc.

LENDER ADDRESS: 111 E. Broadway, Suite 200 Salt Lake City, UT 84111

DATE: 4/18/2019

This agreement ("Contractor Acknowledgement") is made by the above named contractor ("Contractor"). The Contractor in consideration of the above named borrower(s) ("Borrower") agree with the intent to be legally bound, agrees as follows:

Construction Loan

Borrower has applied to Lender for a construction loan ("Loan"). Borrower intends to pay the Contract price, using proceeds of the Loan from Lender. Lender will make the Loan in accordance with the terms of a construction loan agreement ("Loan Agreement").

Construction Loan Agreement

Upon the Borrower's consummation of the Loan Agreement, Contractor shall perform the terms of the Contract in a manner consistent with the Loan Agreement as stated in this Contractor Acknowledgement. If any terms of the Contract conflict with the Loan Agreement or this Contractor Acknowledgement, the terms of the Loan Agreement and this Contractor Acknowledgement shall prevail. Capitalized terms not defined in this Contractor Consent shall have the meaning defined in the Loan Agreement.

Construction Contract

Borrower and Contractor have entered into a construction contract ("Contract"). Under the Contract, Contractor agrees to furnish labor and materials to construct certain improvements ("Improvements") on the Property ("Work") and Borrower agrees to pay Contractor Contract price. Contractor intends to contract with others to supply materials and labor for the Work (each, a "Supplier"). Contractor agrees that the Contract is a fixed price Contract and may not exceed the Contract price stated on page one (1) of this document with the exception of Change Orders provision outlined in this Contractor Acknowledgement.

Loan Administration

Lender's construction loan management company Land Gorilla ("Management Company") will provide construction loan administration services on behalf of the lender to administer the Loan. To facilitate loan administration, Lender has provided Borrower and Contractor with guidelines in the construction loan information guide ("Guide").

Construction Loan Information Guide

Upon Borrower's execution of the Loan Agreement, Contractor shall perform the Contract in a manner consistent with the Guide and this Contractor Acknowledgement. If any terms of the Contract conflicts with the Guide, the terms

of the Guide shall prevail. If any terms of the Guide conflict with the Loan Agreement, the terms of the Loan Agreement shall prevail. If any terms of the Guide conflict with the Loan Agreement or Contractor Acknowledgement, the Loan Agreement and Contractor Acknowledgement shall prevail.

Arbitration Agreements

Claims or disputes arising out of or relating to the Contract shall be resolved by the Construction Industry Arbitration Rules of the American Arbitration Association ("AAA") unless both Borrower and Contractor mutually agree to other methods and this Method is acceptable to the Lender. The notice of the demand for arbitration must be served on and filed in writing with the other party to this Agreement and with the AAA and must be made in a reasonable time after the dispute has arisen. The award rendered by the arbitrator(s) will be considered final and judgment may be entered upon it in accordance with applicable law in any Court having jurisdiction thereof.

The Work

Upon execution of the Loan Agreement, the Contract shall be amended to include this Contractor Acknowledgement.

Construction Budget and Advancements of the Loan

The Work shall proceed in accordance with

- the blueprints, shop drawings, plans and specifications for the Work ("Plans");
- the written itemization of the Work and the Contract Price ("Construction Budget"); and
- the itemized description of each segment of the Work that sets the corresponding payment advancements as specified in the Construction Budget accepted by the Lender.

Contract Time and Completion Date

The Work will begin promptly after the execution of the Loan Agreement and will continue diligently in a good and workmanlike manner. The Work will be completed on or before the Completion Date as provided in the Loan Agreement unless extended by Lender in writing in accordance with the Loan Agreement.

Change Orders

Any change in the Contract Price, change in the Work or change in the contract time must be set forth in a change order signed by Borrower and Contractor ("Change Order"). All Change Orders must be provided to and accepted by the Management Company prior to the change.

Insurance During the Construction Phase

Contractor shall keep in place an active policy for Contractor's General Liability Insurance and Workmens Compensation Insurance in accordance with the Loan Agreement.

Borrower shall get and keep in place an active policy for Borrower's Builders Risk Insurance in accordance with the Loan Agreement.

Construction Pre-Starts

Contractor shall warrant that no labor has been performed or furnished and no materials have been delivered to the property and that no labor will be performed or furnished and no materials will be delivered prior to the recording of the Lender's security instrument. In the event Contractor becomes aware of labor or materials furnished to the property before the recording of the Lender's security instrument the Contractor will immediately notify the Lender.

Construction Loan Disbursement Request (Draw Request)

Contractor shall provide Borrower the application for payment ("Draw Request") in the form provided by the Management Company unless an alternative process is agreed to by Lender and Borrower.

Limits on Construction Loan Draw Requests

No More than one Draw Request shall be submitted in any calendar month.

Lender shall calculate the amount of each Draw Request in accordance with the Loan Agreement.

After the Draw, the Loan Commitment Amount remaining will be sufficient to complete all Improvements described in the Loan Agreement, the Plans and the Construction Contract.

Final Disbursement will not be less than ten (10%) of the Contract amount.

Each Draw Request must be accompanied by a lien waiver or lien release, satisfactory to the Management Company, Lender and Title Company.

Borrower's Default

In the event Lender takes possession of the property, Contractor agrees to the Borrower's Assignment of the Construction Contract to Lender. Contractor agrees to perform on Lender's behalf all obligations under the Construction Contract in the event of any default by Borrower under the Loan Agreement.

Notices

Any communication required by this Contractor Acknowledgement shall be in writing and address to the addressee at the address indicated on the first page of this document.

Governing Law

This Contractor Acknowledgement is entered into in the state where the Property is located (the "State") and shall be controlled and interpreted by the laws of the United States and the State.

Successors

Except as otherwise provided herein, this Contractor Acknowledgement shall be binding upon, and shall inure to the benefit of, Contractor and its successors and permitted assigns.

Headings

The headings of sections contained in this Contractor Acknowledgement are provided for convenience only. They form no part of this Contractor Acknowledgement and shall not affect its construction or interpretation.

Counterparts

This Contractor Acknowledgement may be executed in any number of counterparts; each of which when executed and delivered shall be an original, but such counterparts shall together constitute one and the same agreement. Signature pages may be detached from the counterparts and attached to a single copy of this Contractor Acknowledgement to physically form one document.

Entire Agreement

This Contractor Acknowledgement and the Loan Agreement represent the final agreement between the Borrower and Contractor and may not be contradicted by evidence of prior, contemporaneous or subsequent oral agreements of the parties, and may be amended only by contemporaneous or subsequent written agreement signed by both the Borrower and Contractor with the acceptance of such written agreement accepted by the Lender. Contractor acknowledges that the execution and delivery of this Contractor Acknowledgement is its free and voluntary act and deed, and that said execution and delivery have not been induced by, nor done in reliance upon, any promises, representations, warranties, understandings or agreements made by Lender, its agents, officers, employees or representatives other than those stated in this Contractor Acknowledgement.

Modifications

No promise, representation, warranty or agreement made subsequent to the execution and delivery of this Contractor Acknowledgement by the Contractor hereto, and no revocation, partial or otherwise, or change, amendment or addition to, or alteration or modification of, this Contractor Acknowledgement shall be valid unless the same shall be in writing signed by duly authorized officers of Contractor.

Severable Provisions

If any one or more of the covenants, agreements, provisions, or terms of this Contractor Acknowledgement shall be for any reason whatsoever held invalid, then such covenants, agreements, provisions, or terms shall be deemed severable from the remaining covenants, agreements, provisions, or terms of this Contractor Acknowledgement and shall in no way affect the validity or enforceability of the other provisions of this Contractor Acknowledgement.

Signature

Contractor acknowledges that they have read and fully understand all terms and conditions of this Contractor Acknowledgement.

CONTRACTOR NAME: Muddy River Contractors, LLC

BY: Clarence Lewis Clarence Lewis

ITS: Manager member

LICENSE NUMBERS: NV Lic # 0069191 B-2, NV Lic # 0069524 A-Gen

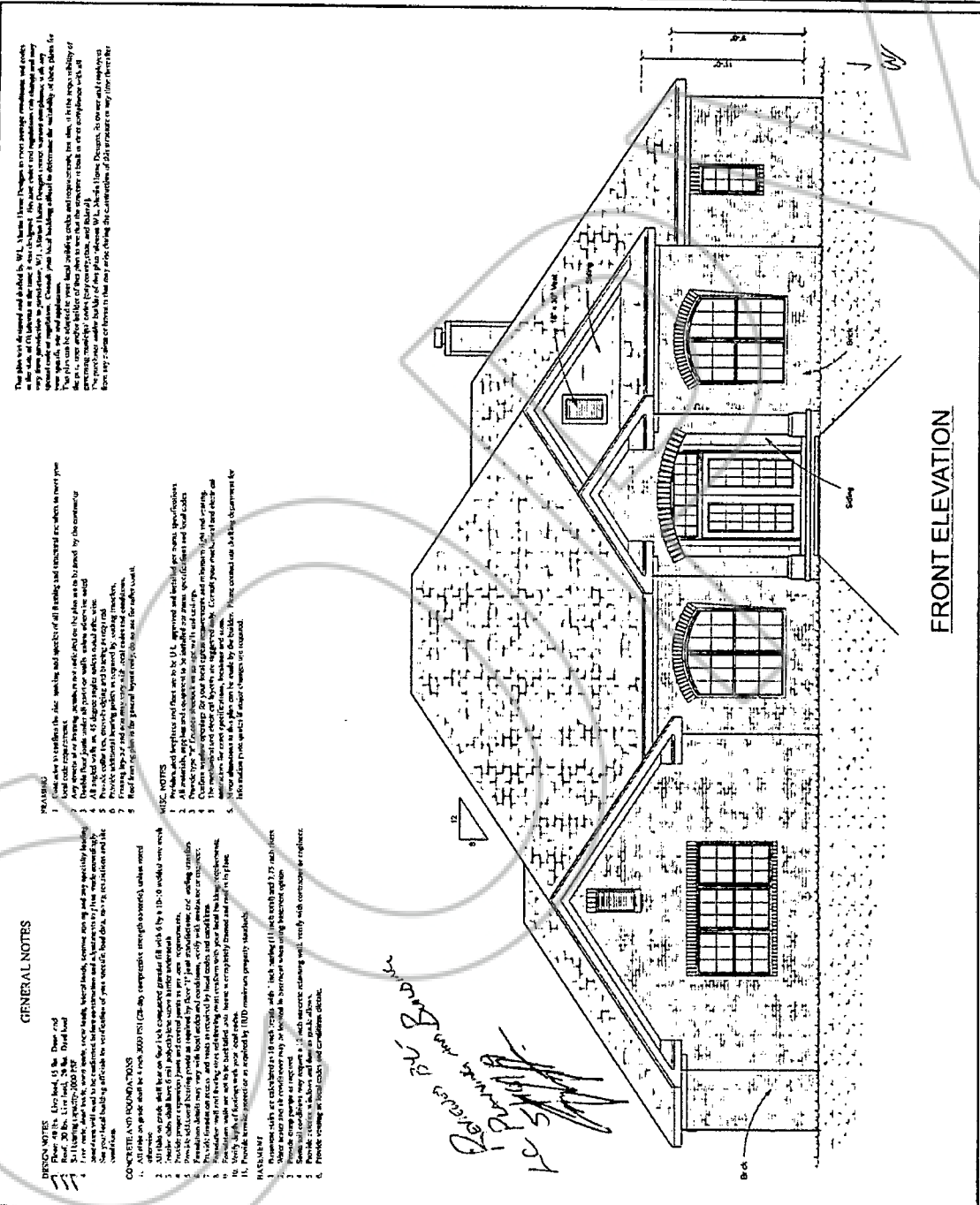

FRONT ELEVATION

The plan was designed and drafted by W.L. Martin Home Designs in every respect. The drawings and notes are the property of W.L. Martin Home Designs. No part of this drawing may be reproduced, stored in a retrieval system, or transmitted in any form or by any means, electronic, mechanical, photocopying, recording, or by any information storage and retrieval system, without the prior written permission of W.L. Martin Home Designs.

FRAMING
 1. Use selective treatment of the finish and species of all framing and structural elements in every part of the structure.
 2. Any species of framing or finish not specified in the plan is to be used by the contractor.
 3. All framing shall be installed in accordance with the manufacturer's instructions.
 4. All framing shall be installed in accordance with the manufacturer's instructions.
 5. Provide additional bracing where required by building codes.
 6. Read from top plan for the general layout and details for all framing.

GENERAL NOTES
 1. All work shall be in accordance with the latest editions of the International Building Code (IBC) and the International Residential Code (IRC).
 2. All work shall be in accordance with the latest editions of the International Building Code (IBC) and the International Residential Code (IRC).
 3. All work shall be in accordance with the latest editions of the International Building Code (IBC) and the International Residential Code (IRC).

CONCRETE AND FOUNDATIONS
 1. All concrete shall be in accordance with the latest editions of the International Building Code (IBC) and the International Residential Code (IRC).
 2. All concrete shall be in accordance with the latest editions of the International Building Code (IBC) and the International Residential Code (IRC).
 3. All concrete shall be in accordance with the latest editions of the International Building Code (IBC) and the International Residential Code (IRC).

FINISHES
 1. All finishes shall be in accordance with the latest editions of the International Building Code (IBC) and the International Residential Code (IRC).
 2. All finishes shall be in accordance with the latest editions of the International Building Code (IBC) and the International Residential Code (IRC).
 3. All finishes shall be in accordance with the latest editions of the International Building Code (IBC) and the International Residential Code (IRC).

REVISIONS
 BY: _____
 DATE: _____
 DESCRIPTION: _____

REVISIONS	BY

#24088 - Blakely
Modified For Walch

W.L. Martin Home Designs
for Contact Information
www.wlmarthomes.com

DRW	Scale 1/4" = 1'-0"
Drawn	
Job	
Sheet 2	
Of 7 Sheets	

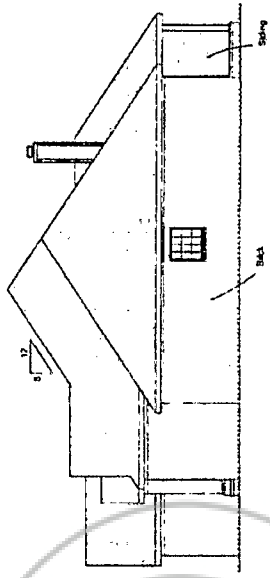

RIGHT SIDE ELEVATION 18' x 14'

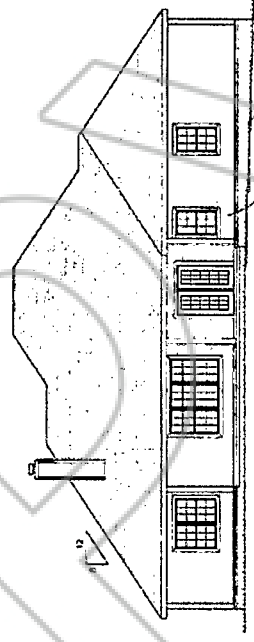

REAR ELEVATION 18' x 14'

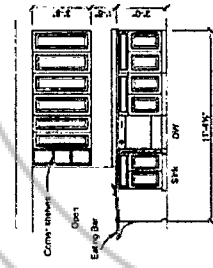

ELEVATION B 18' x 14'

Selections to be made for Cabinet Style, Color, and Hardware

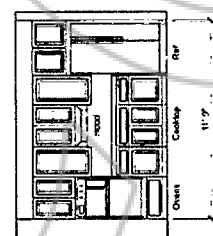

ELEVATION A 18' x 14'

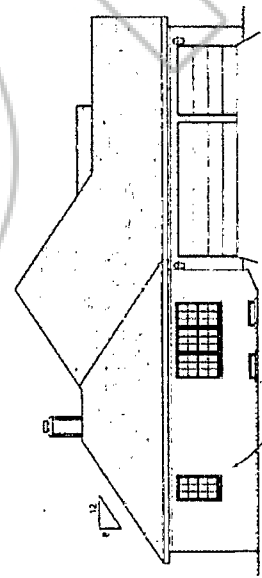

LEFT SIDE ELEVATION 18' x 14'

REVISIONS	BY	

W.T. Martin Home Designs
 for Contact Information
 www.wmartinhomes.com
 #24088 - Blakely
 Modified For Walch

Date
 Scale 1/4" = 1'-0"
 Drawn
 Job
 Sheet 3
 of 7 Sheets

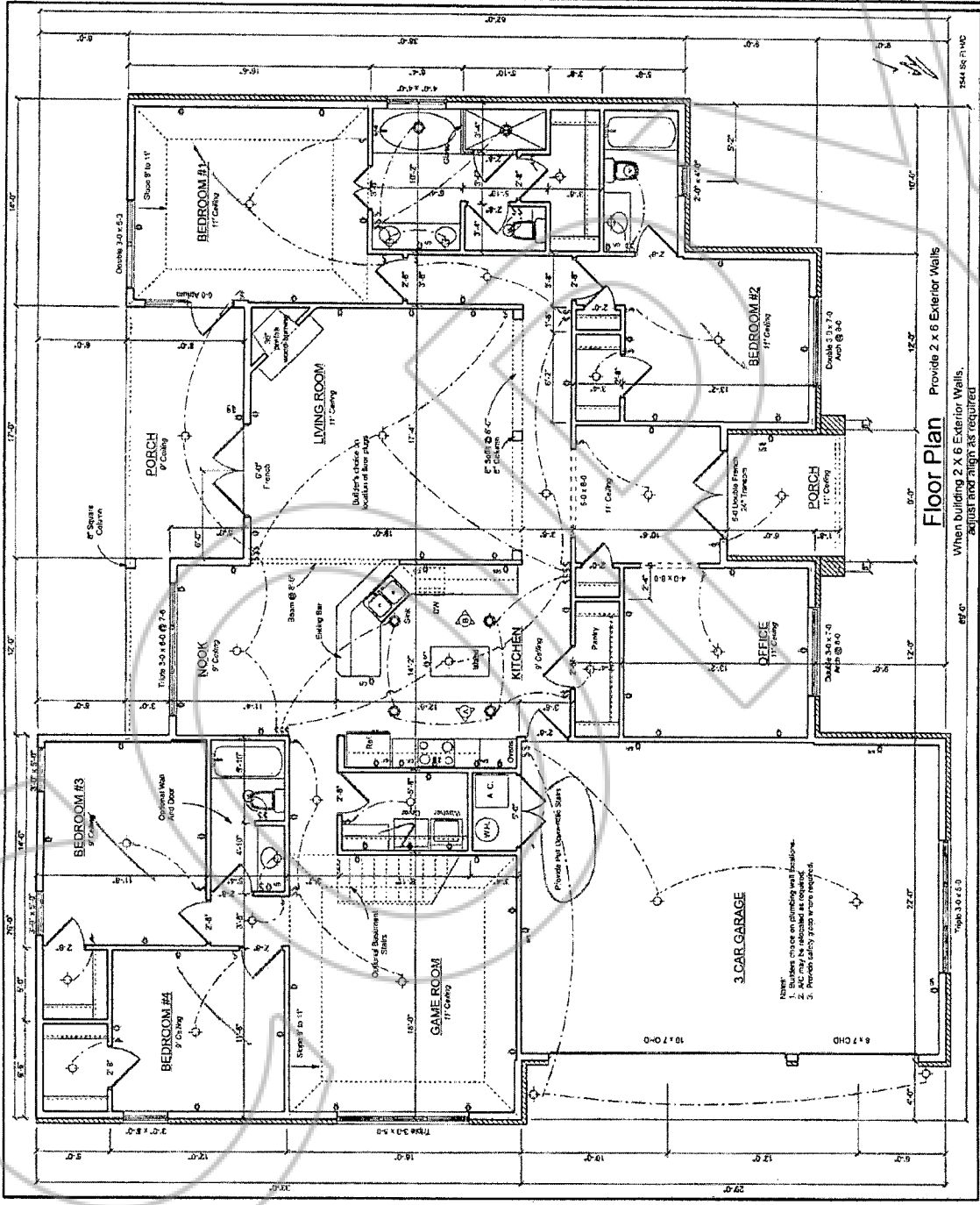

1 2 571 858
 2492 / 350

REVISIONS	BY

W.L. Martin Home Designs
 for Contact Information
 www.wlmarthomes.com

Date: _____
 Scale: 1/4" = 1'-0"
 Sheets: _____
 Job: _____
 Sheet: 4
 Of: 7 Sheets

NOTE: ALL STRUCTURAL MEMBERS MUST COMPLY W/ LOCAL BUILDING CODES.

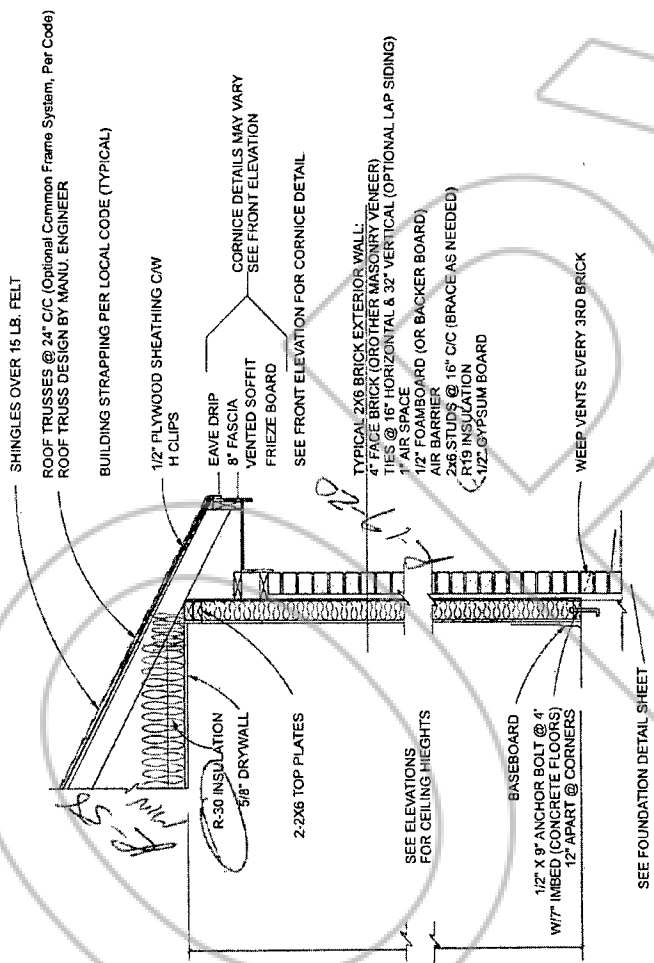

TYPICAL BUILDING SECTION
 2 x 6 Exterior Stud

W.L. MARTIN HOME DESIGNS DOES NOT MAKE ANY GUARANTEE OF THE ACCURACY OF THIS SET OF PLANS. BEFORE CONSTRUCTION THE CONTRACTOR SHALL VERIFY ALL DIMENSIONS, CHECK DIMENSIONS AND LOADS, AND VERIFY ALL MATERIALS AND METHODS OF CONSTRUCTION AGAINST ALL APPLICABLE LOCAL, STATE AND FEDERAL BUILDING CODES AND REGULATIONS.

SEE FOUNDATION DETAIL SHEET

SEE ELEVATIONS FOR CEILING HEIGHTS

SEE FRONT ELEVATION FOR CORNICE DETAIL

CORNICE DETAILS MAY VARY SEE FRONT ELEVATION

1/2" PLYWOOD SHEATHING CW H CLIPS

BUILDING STRAPPING PER LOCAL CODE (TYPICAL)

ROOF TRUSSES @ 24" C/C (Optional Common Frame System, Per Code)

SHINGLES OVER 15 LB. FELT

BASEBOARD
 1/2" X 9" ANCHOR BOLT @ 4'
 W/ 7" IMBED (CONCRETE FLOORS)
 12" APART @ CORNERS

WEEP VENTS EVERY 3RD BRICK

2x6 STUDS @ 16" C/C (BRACE AS NEEDED)
 R19 INSULATION
 1/2" GYPSUM BOARD

TYPICAL 2x6 BRICK EXTERIOR WALL:
 4" FACE BRICK (OR OTHER MASONRY VENEER)
 TIES @ 16" HORIZONTAL & 32" VERTICAL (OPTIONAL LAP SIDING)
 1" AIR SPACE
 1/2" FOAMBOARD (OR BACKER BOARD)
 AIR BARRIER

2-2x6 TOP PLATES

R-30 INSULATION
 5/8" DRYWALL

EAVE DRIP

8" FASCIA

VENTED SOFFIT

FRIEZE BOARD

REVISIONS	BY

#24088
Blakely

W.L. Martin Home Designs
for Contact Information
www.whmartinhome.com

Date	
Scale	
Drawn	
App	
Sheet	5
Of	7 Sheets

NOTE: SEE ADDITIONAL NOTES ON FRONT ELEVATION SHEET.

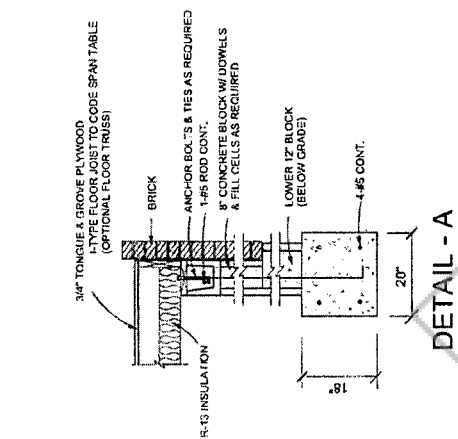

DETAIL - A

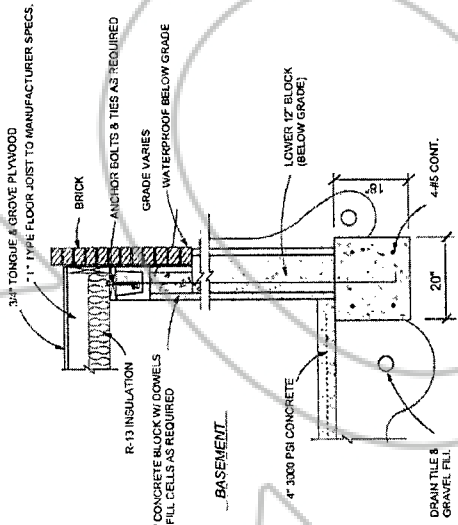

OPTIONAL BASEMENT SECTION

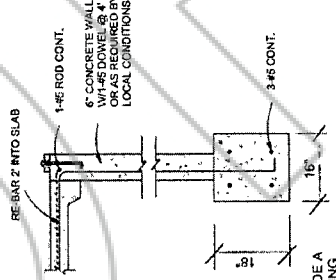

DETAIL - B

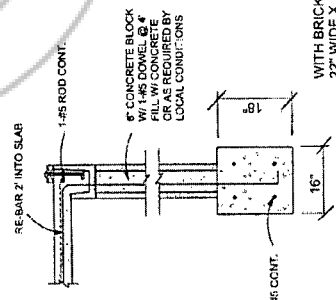

DETAIL - C

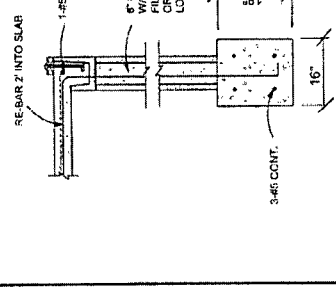

DETAIL - D

1 STORY FOUNDATION DETAILS (OPTIONS)

- NOTES:
- * WALLS ABOVE 4'-0" FROM FINISH GRADE MAY REQUIRE ADDITIONAL STRUCTURAL SIZING. SEE ENGINEER
 - * IF FOOTING SIZE & RETAINING WALL REQ.)
 - * VERIFY WITH CONTRACTOR OR ENGINEER
 - * CONCRETE FLOOR TO BE 8" MINIMUM
 - * PROVIDE COMPACTED SAND FILL AS REQUIRED UNDER FOOTINGS.

W.L. MARTIN HOME DESIGNS DOES NOT WARRANT THE ACCURACY OF THESE FOUNDATION DETAILS. CONTRACTOR, ENGINEER, OR ARCHITECT MUST VERIFY THAT THESE PLANS COMPLY WITH ALL BUILDING CODES IN EFFECT AT CONSTRUCTION LOCATION.

REVISIONS	BY

#24088
Blakely

W.L. Martin Home Designs
for Contact Information
www.wlmartinhomes.com

Date _____
Scale 1/4" = 1'-0"
Drawing _____
Job _____
Sheet 6
of 7 sheets

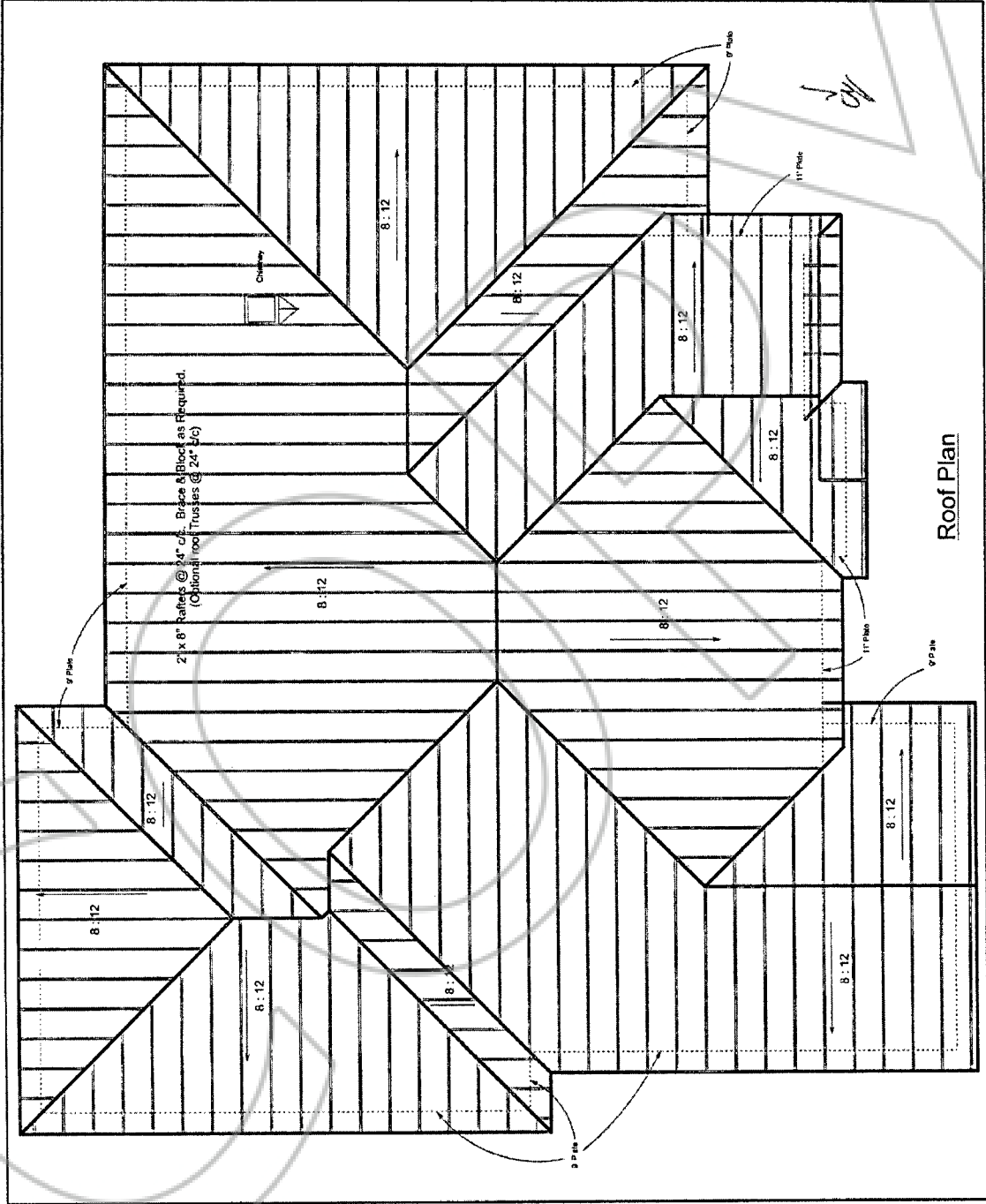

Roof Plan

REVISIONS	BY

#24088 - Blakey
Modified For Walch

W.T. Martin Home Designs
for Contact Information
www.wtmartinhomes.com

Date: Scale: 1/4" = 1'-0"
Drawn: Job: Sheet: 7B
01 7 Sheets

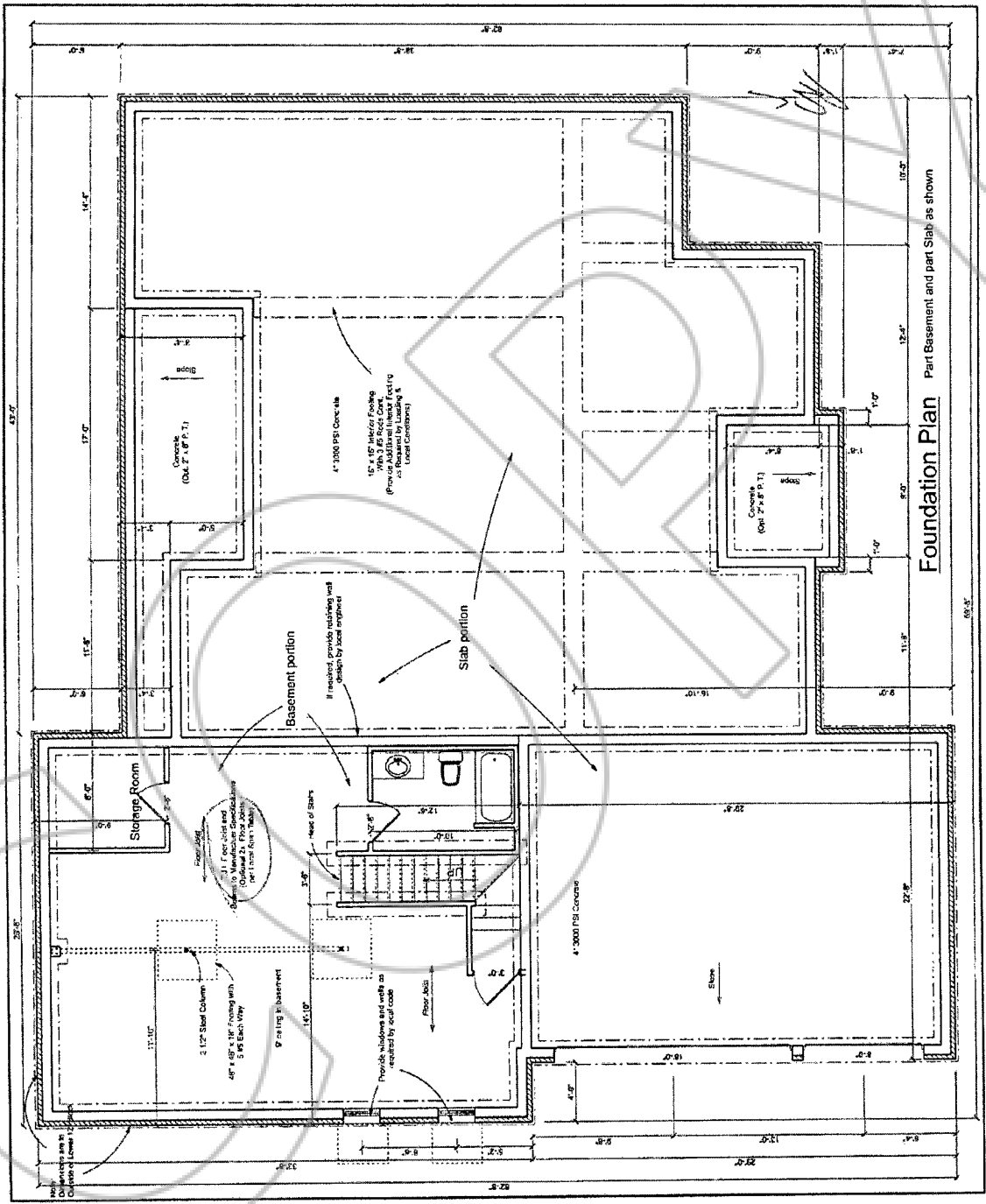

Foundation Plan Part Basement and part Slab as shown

86'-3"

OWNER:
QUINN + CHRISANNE WALCH

ADDRESS:
120 LAMB BLVD
ALAMO, NV 89001

PARCEL NO.:
004-141-75

WATER SERVICE

POWER POLE

ELECTRICAL SERVICE

SEPTIC SYSTEM

HOUSE

GRAVEL DRIVEWAY

30'-0"
(SET BACK)

26'-0" (SET BACK)

7.5'-0"
(SET BACK)

SITE PLAN

SCALE: 1/4" = 10'

