

Deed of Dedication

Known by all men by these presents, that the undersigned **Gary A. Carrigan, Trustee of the 5 C Carrigan Trust**, does hereby dedicate to the County of Lincoln, State of Nevada a strip of land for public use as a public right-of-way, being more particularly described as follows:

APN 013-160-28

See Exhibit's 'A' & 'B'

IN WITNESS WHEREOF: The undersigned have executed this Deed of Dedication on

this 3rd day of June, 2002.

Gary A. Carrigan Trustee
Gary A. Carrigan, Trustee, of the 5 C Carrigan Trust

State of Nevada }
 } SS
 County of Lincoln }

On this 3rd day of June, 2002, personally appeared before me, a Notary Public, **Gary A. Carrigan, Trustee of the 5 C Carrigan Trust**, who acknowledged that they executed the above instrument.

Trista Fogliani
 Notary Public for and in said county and state



RECORDER'S USE ONLY

When Recorded Send To:
 Gary Carrigan
 P.O. Box 381
 Pioche, NV 89043

MAP SHOWING A RIGHT-OF-WAY TO BE ACQUIRED FROM
CARRIGAN 5 C TRUST

FOR
SUNRISE DRIVE AND MICHAEL'S WAY

SITUATED WITHIN PARCELS 8&12 OF DIVISION OF LARGE PARCELS,
 BOOK PLAT B, PAGE 54, AND PARCELS 9&11 OF SUBSEQUENT
 PARCEL MAP BOOK PLAT B, PAGE 250, WITHIN SEC. 11,
 T. 3 S., R. 67 E., M.D.M., LINCOLN COUNTY, NEVADA

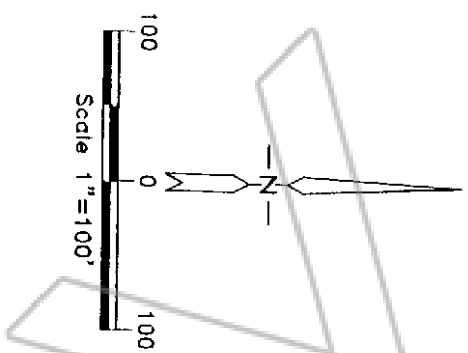

APN 013-160-28
 PARCEL 8
 OF DIVISION OF LARGE PARCELS
 BOOK PLAT B, PAGE 54
 CARRIGAN 5 C TRUST

APN 013-160-58
 PARCEL 9
 OF SUBSEQUENT PARCEL MAP
 BOOK PLAT B, PAGE 250
 CARRIGAN 5 C TRUST

APN 013-160-59
 PARCEL 11
 OF SUBSEQUENT PARCEL MAP
 BOOK PLAT B, PAGE 250
 CARRIGAN 5 C TRUST

APN 013-160 32
 PARCEL 12
 OF DIVISION OF LARGE PARCELS
 BOOK PLAT B, PAGE 54
 CARRIGAN 5 C TRUST

$\Delta=81^{\circ}05'34''$
 $R=60.00'$
 $L=63.98'$
 $T=35.41'$

S 89°34'55" W
 1266.09'
SUNRISE DRIVE
 1236.09'
 S 89°34'55" W
 1318.45'

0.93 AC/40688 SF
 60.00'
 N 01°30'59" W
 60.00'

DEDICATED 30' RIGHT-OF-WAY
 30.00'
 P.O.B.

S 89°34'55" W
 30.00'

0.46 AC/ 20002 SF 577.35'
 S 01°10'09" E
MICHAEL'S WAY
 659.71'
 S 01°10'09" E
 659.71'
 0.46 AC/ 19992 SF 578.14'
 S 01°10'09" E

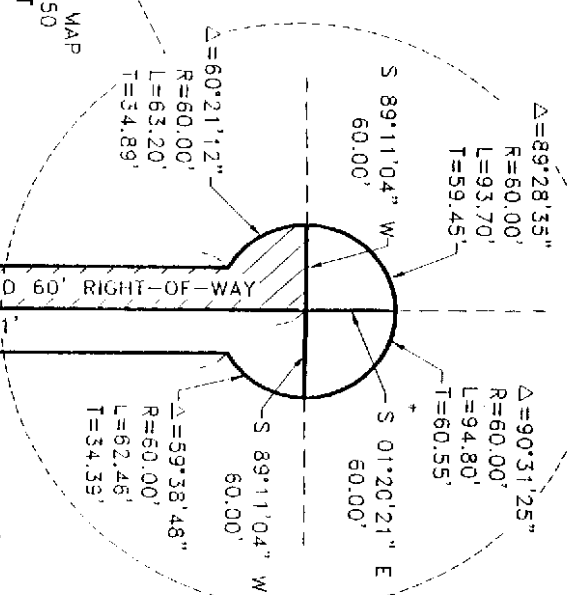

Legal Description of Sunrise Drive

A strip of land 30.00 feet wide for the purpose of a public road way, being situated within Parcel 8 of Division of Large Parcels, book plat B, page 54, Sec. 11, T. 3 S., R. 67 E., M.D.M., being more particularly described as follows:

Beginning at the SE Corner of said parcel of land;
Thence S. 89°34'55" W. a distance of 1318.45 feet to the SW Corner of said strip of land and the SW Corner of said Parcel 8;
Thence N. 01°30'59" W. a distance of 60.00 feet to a point of curve
Thence along a curve in a southeasterly direction having a central angle of 61°05'54", a radius of 60.00 feet, a curve length of 63.98 feet and a tangent length of 35.41 feet;
Thence N. 89°34'55" E. a distance of 1236.09 feet to the NE Corner of said strip of land;
Thence S. 01°10'09" E. a distance of 30.00 feet to the said SE Corner of Parcel 8 and point of beginning;

Containing 0.93 Acre or 40688 Square Feet, more or less.

Legal Description of Michael's Way

A strip of land 30.00 feet wide for the purpose of a public road way, being situated within Parcel 8 of Division of Large Parcels book plat B, page 54, Sec. 11, T. 3 S., R. 67 E., M.D.M., being more particularly described as follows:

Beginning at a point on the northerly right-of-way of Sunrise Drive, whence the SE Corner of said Parcel 8 bears S. 01°10'09" E. a distance of 30.00 feet
Thence S. 89°34'55" W. a distance of 30.00 feet to the SW Corner of said strip of land;
Thence N. 01°10'09" W. a distance of 577.35 feet to point of curve;
Thence along a curve in a northerly direction having a central angle of 60°21'12", a radius of 60.00 feet, a length of 63.20 feet and a tangent length of 34.89 feet to the NE Corner of said Parcel 8;
Thence S. 01°10'09" E. a distance of 659.71 feet to the SE Corner of said strip of land and point of beginning;

Containing 0.46 Acre or 20002 Square Feet, more or less.

FILED FOR RECORDING
AT THE REQUEST OF
Lincoln County
2002 JUN 13 PM 2 03
LINCOLN COUNTY RECORDED
FEE DEP TMS
LESLIE BOUCHER

118303

BOOK 164 PAGE 301