

PLANNING COMMISSION

At the regular meeting of the Lincoln County Planning Commission meeting held this 16th day of June, 2000, this plat was examined and is recommended for approval.

Walter S. Welfer
Chairman

COUNTY COMMISSION

At the regular meeting of the Lincoln County Commission held this 16th day of June, 2000, this plat was examined and is approved for recording.

Don Fahn *Carina Hagan*
Chairman County Clerk

SURVEYOR'S CERTIFICATE

I, Lenard D. Smith, a Professional Land Surveyor, registered in the State of Nevada, certify that:

- This plat represents the results of a survey conducted under my direct supervision at the instance of Robert J. and Carol Mathews.
- The lands surveyed lie within Section 5, T.2S., R.68E., M.D.M., Lincoln County, Nevada. The survey was completed March 15, 2000.
- This plat complies with applicable state statutes and any local ordinances in effect on the date that the governing body gave its final approval.
- The monuments depicted on the plat are of the character shown, occupy the positions indicated and are of sufficient number and durability.

Lenard D. Smith, P.L.S. 12751

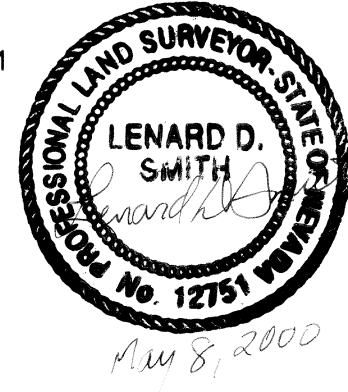

OWNER'S CERTIFICATE

We, Robert J. and Carol Mathews certify that we are the owners of the lands as shown on this plat, and agree to the easement to Parcel 2 as shown for egress, ingress and utilities as may be needed. We have requested Lenard D. Smith, a Professional Land Surveyor to prepare this Plat for recording.

Robert J. Mathews
Robert J. Mathews

Carol Mathews
Carol Mathews

ACKNOWLEDGEMENT

STATE OF Nevada SS
COUNTY OF Lincoln

I certify that the above named persons personally appeared before me, a Notary Public and executed the Owner's Certificate freely and voluntarily for the purposes stated therein.

Janice Barr
Notary Public

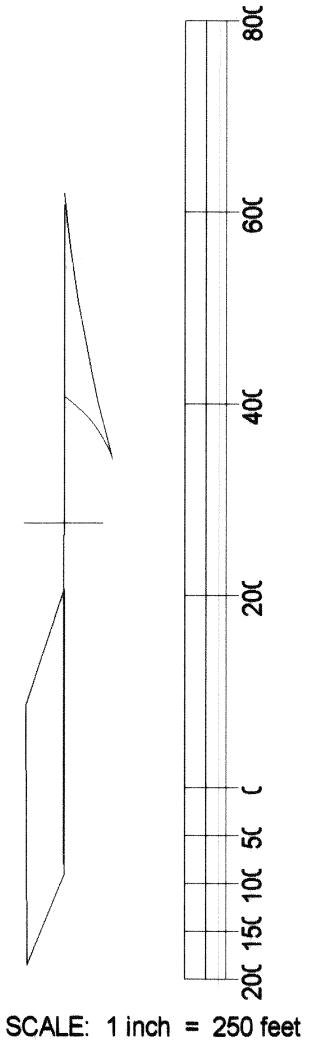

PARCEL 2 DATUM

line no.	bearing	distance
1	N89°54'08"E	56.22'
2	N00°06'16"E	228.40'
3	N89°40'59"W	113.75'
4	N75°17'44"W	44.32'
5	N75°17'44"W	72.48'
6	N00°06'07"E	197.74'
7	N89°54'08"E	170.57'
8	N24°58'37"E	238.75'

PARCEL 1 DEED DESCRIPTION COMPARISON WITH EXISTING FENCE (COMPARES FAVORABLY)

DEED	FENCED PARCEL MEAS.
SW CORNER SEC 5 BEARS S75°34'34"W 2260.33'	SW COR. SEC. 5 BEARS S75°38'40"W 2260.40'
Thence north 198.24'	Thence N0°06'07"E 197.74'
Thence east 228.00'	Thence N89°54'08"E 226.79'
Thence south 228.37'	Thence S0°06'16"W 228.40'
Thence S89°49'36"W 114.38'	Thence N89°40'49"W 113.75'
Thence N82°48'20"W 40.88'	Thence N75°17'44"W 116.6'
Thence N70°51'36"W 77.34'	to the point of beginning.
to the point of beginning.	

LEGEND

- ⊙ Set 5/8" rebar with cap marked L SMITH PLS 12751
- ⊕ Set 5/8" rebar & aluminum cap marked L SMITH PLS 12751

MAP REFERENCES

Refer to AMENDED RECORD OF SURVEY Plat Book B, Page for the Section subdivision details as a basis of measurements for this map.

Boundary Line Adjustment map for Dan & Alice C. Smkins Plat Book B, Page 165, Lincoln Co. Records.

Record of Survey for the Panaca Farmstead Association Plat A, Page 436 of Lincoln County, Nevada Records.

BASIS OF BEARINGS

The east section 8 line, T.2S., R.68E., M.D.M., the SE to NE corners, the BLM Dependent Resurvey, brass cap stamped 1995, recorded as N 0°02'10"E. (The B.L.M. survey is considered a Preliminary record, and not as yet approved).



PARCEL MAP

SHOWING FENCED PARCEL USED BY THE PANACA FARMSTEAD ASSOCIATION

IN THE SE1/4SW1/4 SECTION 5, T.2S., R.68E., M.D.M.

FOR ROBERT J. & CAROL MATHEWS

RECORDER'S CERTIFICATE

File number 114679

Filed at the request of Lenard D. Smith

Filed Plat Book B, Page 313 of Lincoln County, Nevada Records.

Date June 16, 2000 at 3:22 p.m.

LESLIE BOUCHER, Recorder

By *Terese Levers*
Deputy

THIS PLAT SHOWS VICINITY AS WELL AS THE PARCELS

STATE ROUTE 319 (not to scale) PANACA 1/2 MILE

U.S. HIGHWAY 93 (no scale)