

266

SURVEYOR'S CERTIFICATE

I, James J. Owens, a Professional Land Surveyor registered in the State of Nevada, do hereby certify that:

1. This Plat represents the results of a survey conducted by me, or under my direct supervision at the instance of Rainbow Canyon Ranch, L.L.C.
2. The lands surveyed lie within Sec.'s 7,18 & 19, T. 4 S., R. 67 E., M.D.M., and Sec.'s 24,25,26,35 & 36, T. 4 S., R. 66 E., M.D.M., within a portion of the City of Caliente, Lincoln County, Nevada, and the survey was completed on Dec. 17, 1999.
3. This plat complies with the applicable state statutes and any local ordinances in effect on the date that the Governing Body gave its final approval.
4. The monuments depicted on this plat are of the character shown, occupy the positions indicated and are of sufficient number and durability.

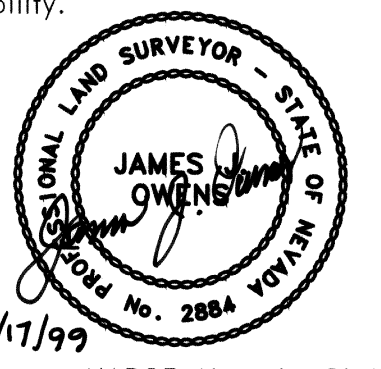

BASIS OF BEARING

The Basis of Bearing was established by G.P.S., using a known NAD83 Nevada State Plane (East Zone) Coordinate on a U.S.G.S. control station described as "COVE".

STATEMENT

Any Subsequent changes to this map should be examined and may be determined by reference to the County Recorder's Cumulative Map Index, N.R.S. 278.5695.

REFERENCE MAPS

1. Field Notes prepared by James J. Owens and Recorded in Book 145, Page 422, Doc. # 113469, dated 12/17/99.
2. Parcel Map Book Plat 'A', Page 228.

LEGEND

- Set 1/2" rebar w/ plastic cap marked "OWENS PLS 2884".
- Set 1" Pipe w/ Alum Cap marked 1/16 "OWENS PLS 2884".
- Found standard B.L.M. B.C. as noted.
- Found standard B.L.M. B.C. as noted.
- └ Depicts Corner not Set.

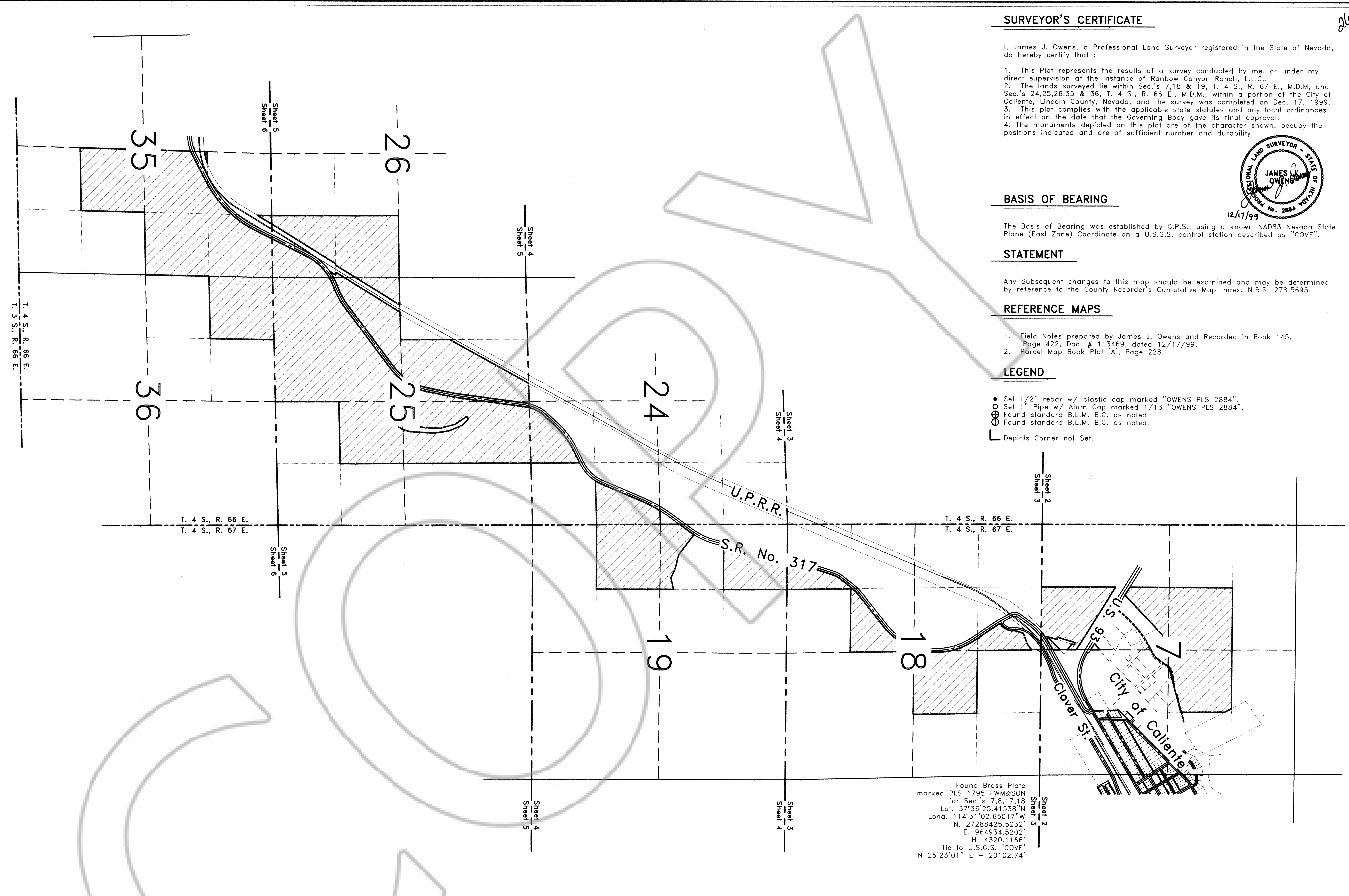

Found Brass Plate
marked PLS 1795 FWM&SON
for Sec.'s 7,8,17,18
Lat. 37°36'25.41538"N
Long. 114°31'02.65017"W
N. 27288425.5232'
E. 964934.5202'
H. 4320.1166'
Tie to U.S.G.S. 'COVE'
N 25°23'01" E - 20102.74'

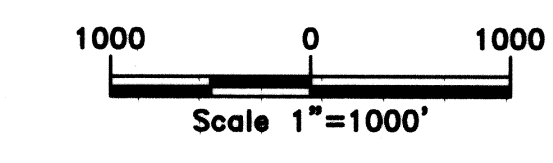
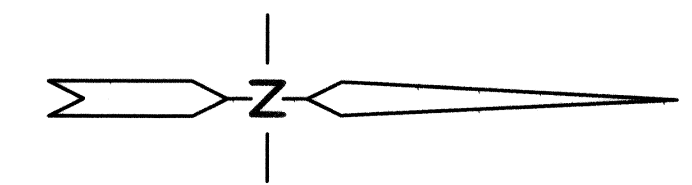

Sheet 1 of 6 Nev-265
S. Hafen

RECORD OF SURVEY

for
Rainbow Canyon Ranch, L.L.C.
Sitated within Sec.'s 7,18 & 19, T. 4 S., R. 67 E., M.D.M.,
and Sec.'s 24,25,26,35 & 36 T. 4 S., R. 66 E., M.D.M.,
within a portion of the City of Caliente, Lincoln County, Nevada

THE OWENS SURVEYING OUTFIT, INC.

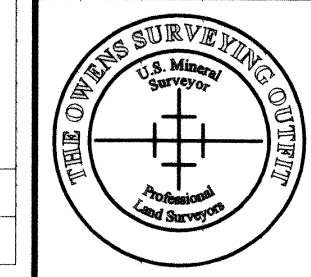

Water Right, Mineral & Land Surveying throughout the West
P.O. Box 540
99 W. Hollywood
Piache, Nevada 89043
Tel : 775-962-5115
Fax : 775-962-5116

266-A

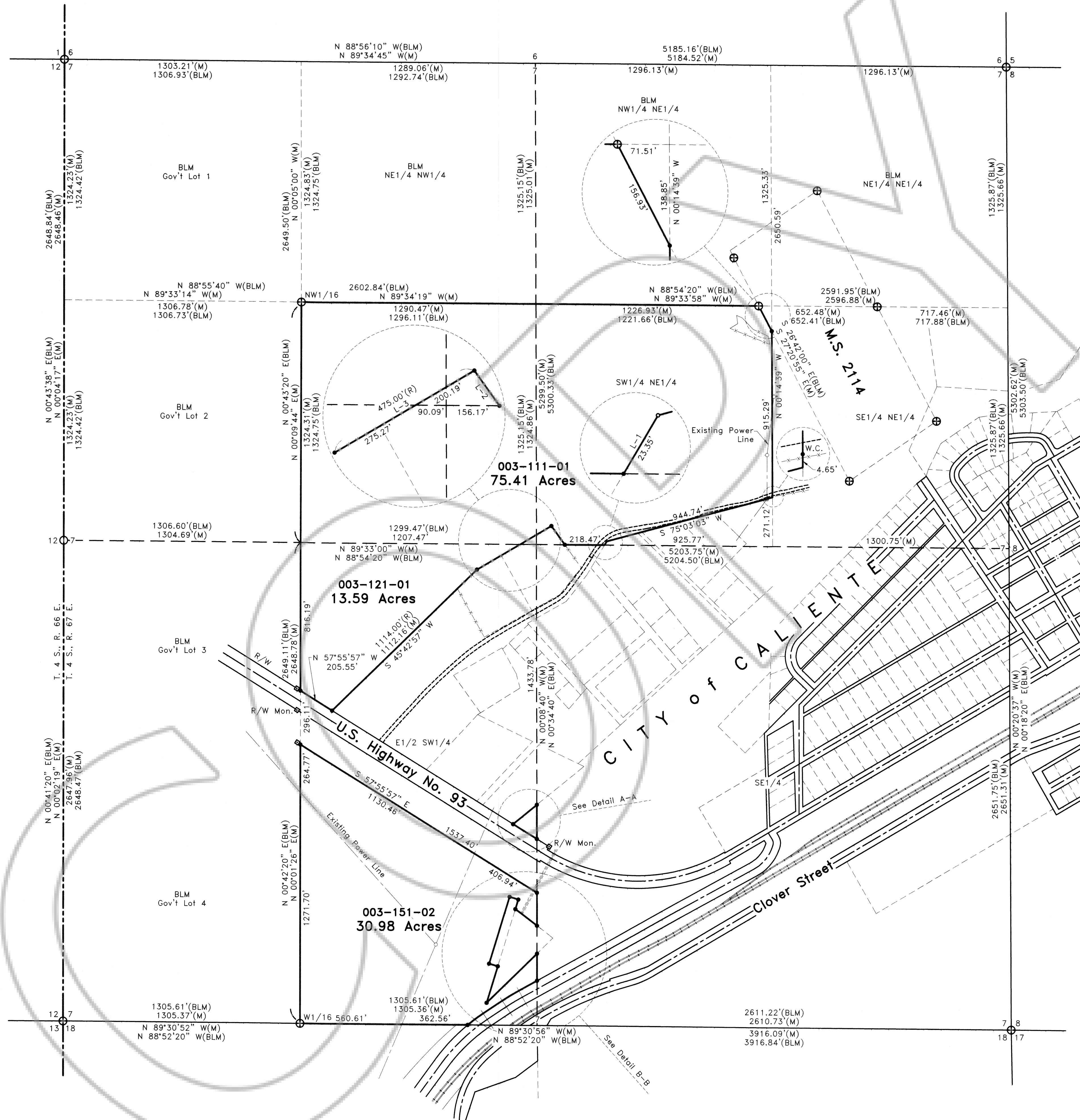

LINE	BEARING	DIST.
L-1	S 30°34'33" W	23.35'
L-2	N 35°36'09" W	126.99'
L-3	S 59°35'45" W	475.46'
L-4	N 52°15'04" W	150.63'
L-5	N 16°59'56" E	55.00'
L-6	N 73°00'04" W	50.00'
L-7	S 73°00'04" E	50.00'
L-8	S 16°59'56" W	210.14'
L-9	S 61°12'20" W	114.37'
L-10	S 56°14'26" W	126.84'

CURVE	DELTA	RADIUS	TANGENT	LENGTH
C-1	04°55'42"	1240.00'	53.36'	106.66'
C-2	05°49'31"	1040.00'	52.92'	105.74'

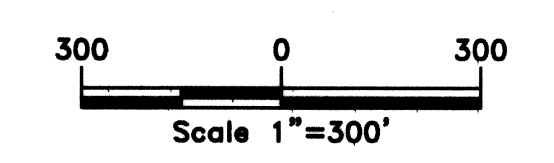
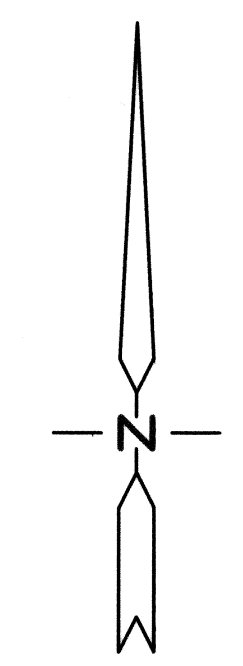
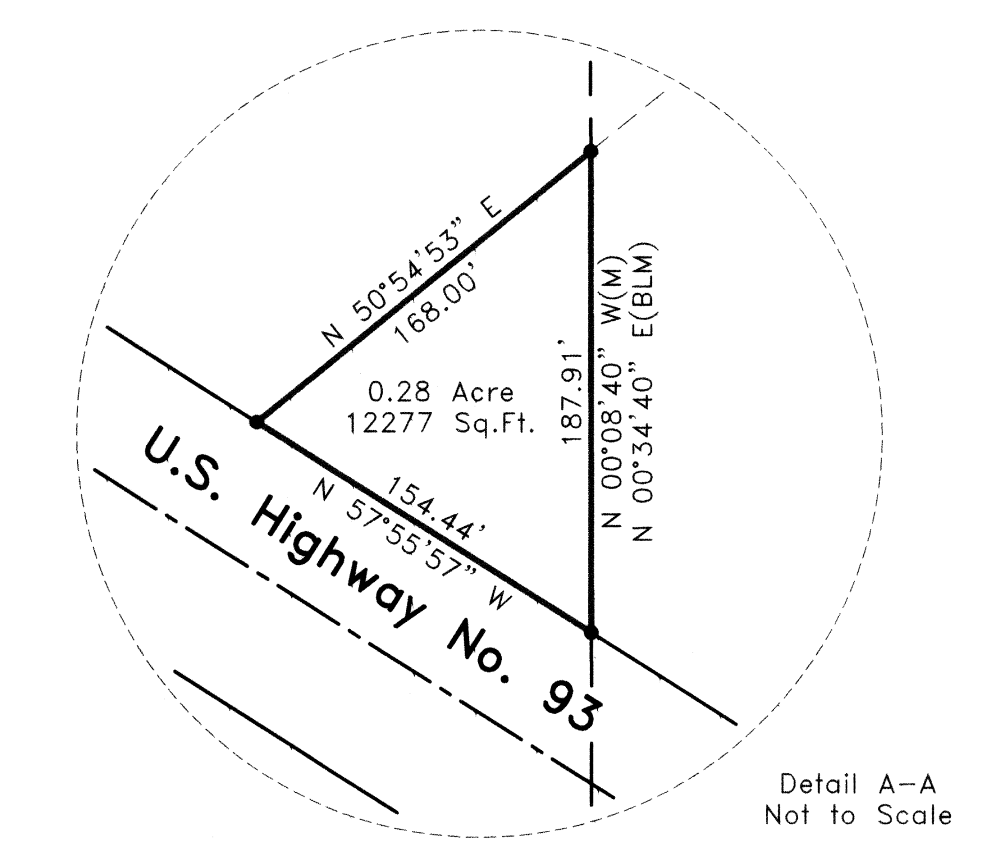
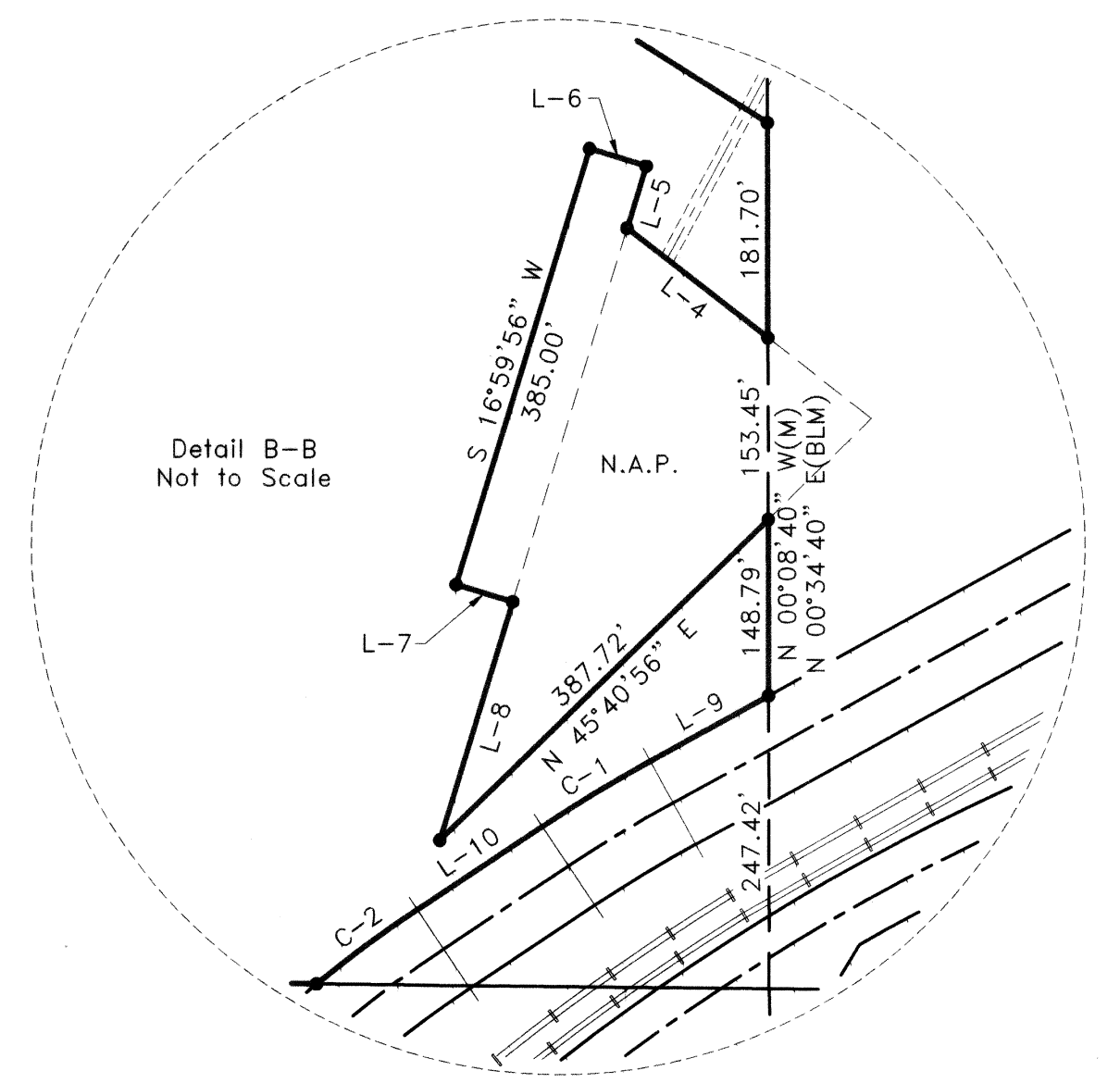

RECORD OF SURVEY
for
Rainbow Canyon Ranch, L.L.C.
Situating within Sec. 7, T. 4 S., R. 67 E., M.D.M.,
City of Caliente, Lincoln County, Nevada

THE OWENS SURVEYING OUTFIT, INC.
Water, Right, Mineral & Land Surveying Throughout the West

P.O. Box 540
99 W. Hollywood
Pioche, Nevada 89043
Tel : 775-962-5115
Fax : 775-962-5116

266-B

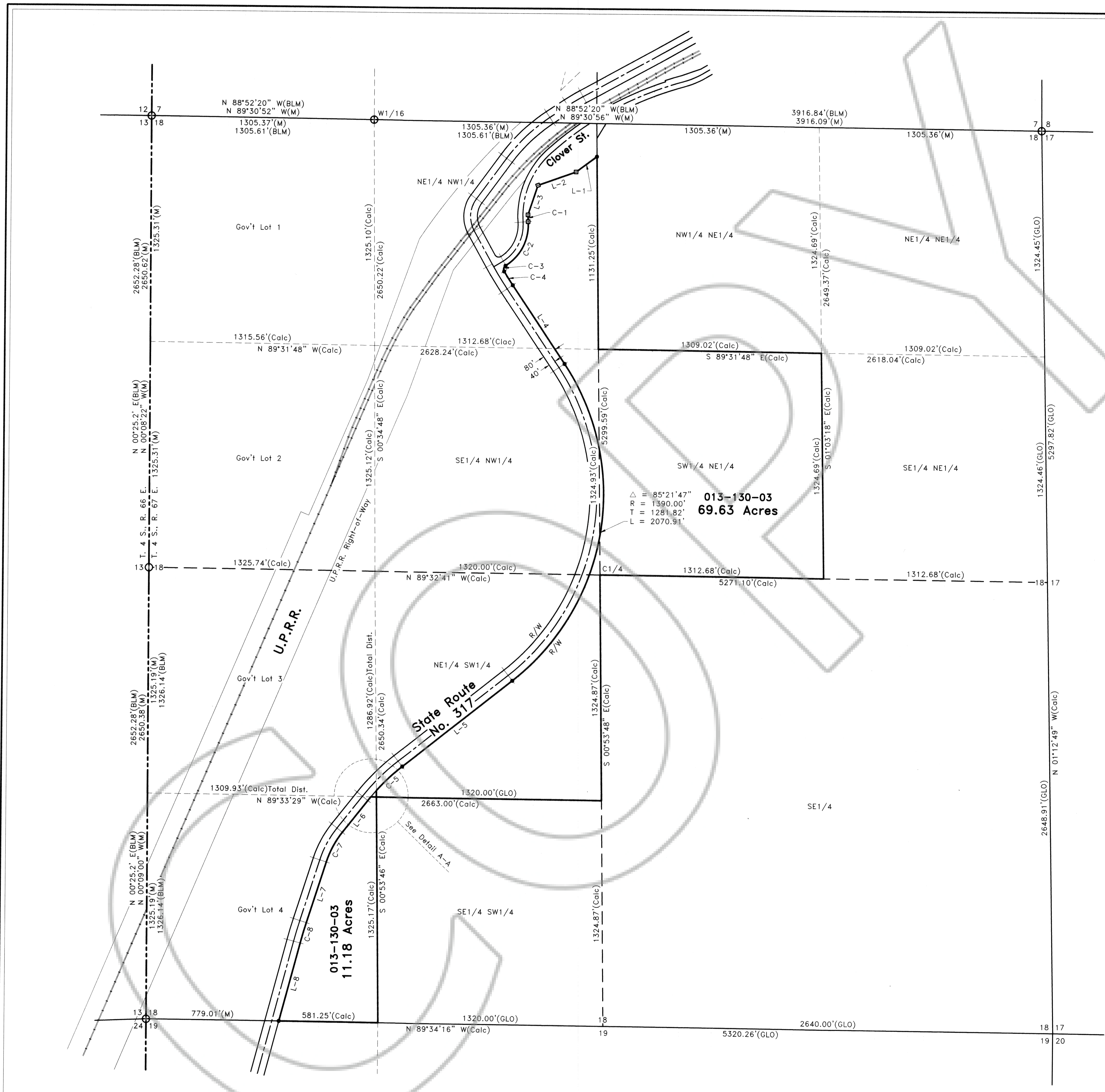

LINE DATA

LINE	BEARING	DIST.
L-1	S 53°01'59" W	152.34'
L-2	S 70°14'54" W	236.89'
L-3	S 18°08'13" W	183.23'
L-4	S 33°49'12" E	552.90'
L-5	S 51°32'35" W	818.20'
L-6	S 38°00'57" W	239.97'
L-7	S 17°41'48" W	375.05'
L-8	S 14°47'09" W	473.77'

CURVE DATA

CURVE	DELTA	RADIUS	TANGENT	LENGTH
C-1	04°55'21"	470.00'	20.20'	40.38'
C-2	62°11'52"	280.00'	168.90'	303.96'
C-3	88°51'24"	25.00'	24.51'	38.77'
C-4	02°47'56"	1960.00'	47.88'	95.75'
C-5	09°50'14"	1210.00'	104.13'	207.75'
C-6	01°19'25"	1210.00'	13.97'	27.95'
C-7	20°19'08"	560.00'	100.35'	198.59'
C-8	02°54'40"	2460.00'	62.51'	124.99'

013-130-03
69.63 Acres

$\Delta = 85^{\circ}21'47''$
 $R = 1390.00'$
 $T = 128^{\circ}82'$
 $L = 2070.91'$

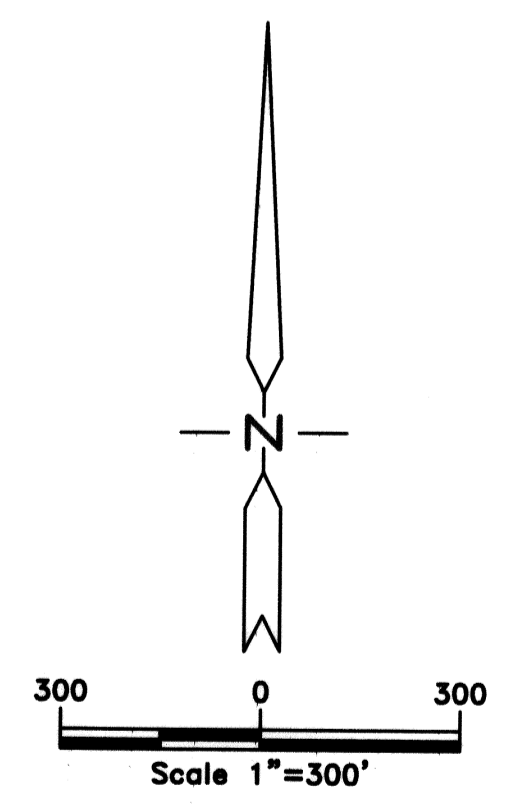
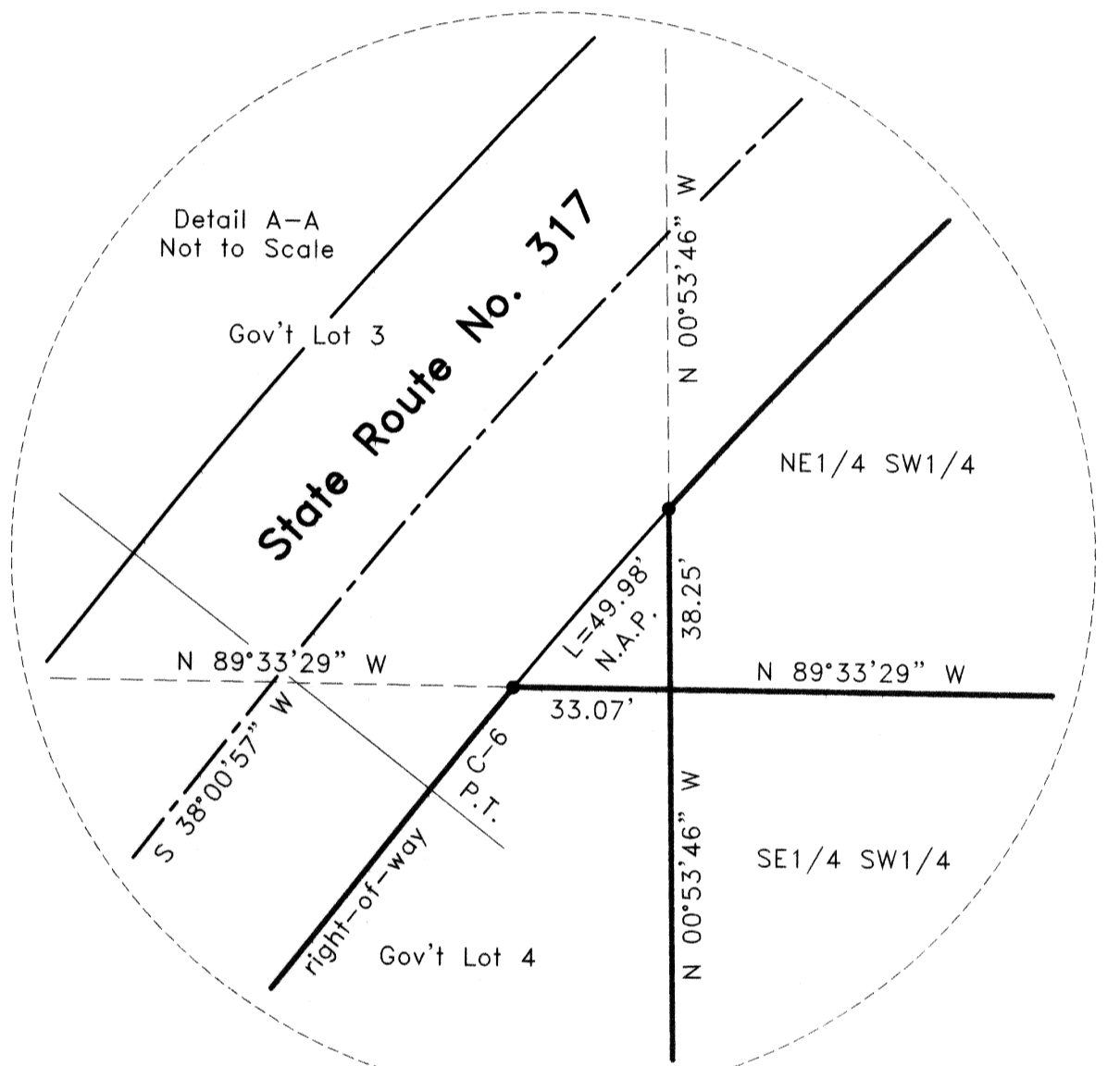

RECORD OF SURVEY
for
Rainbow Canyon Ranch, L.L.C.
Sited within Sec. 18, T. 4 S., R. 67 E., M.D.M.,
Lincoln County, Nevada

THE OWENS SURVEYING OUTFIT, INC.
Water Right, Mineral & Land Surveying throughout the West

P.O. Box 540
99 W. Hollywood
Pioche, Nevada 89043
Tel : 775-962-5115
Fax : 775-962-5116

266-C

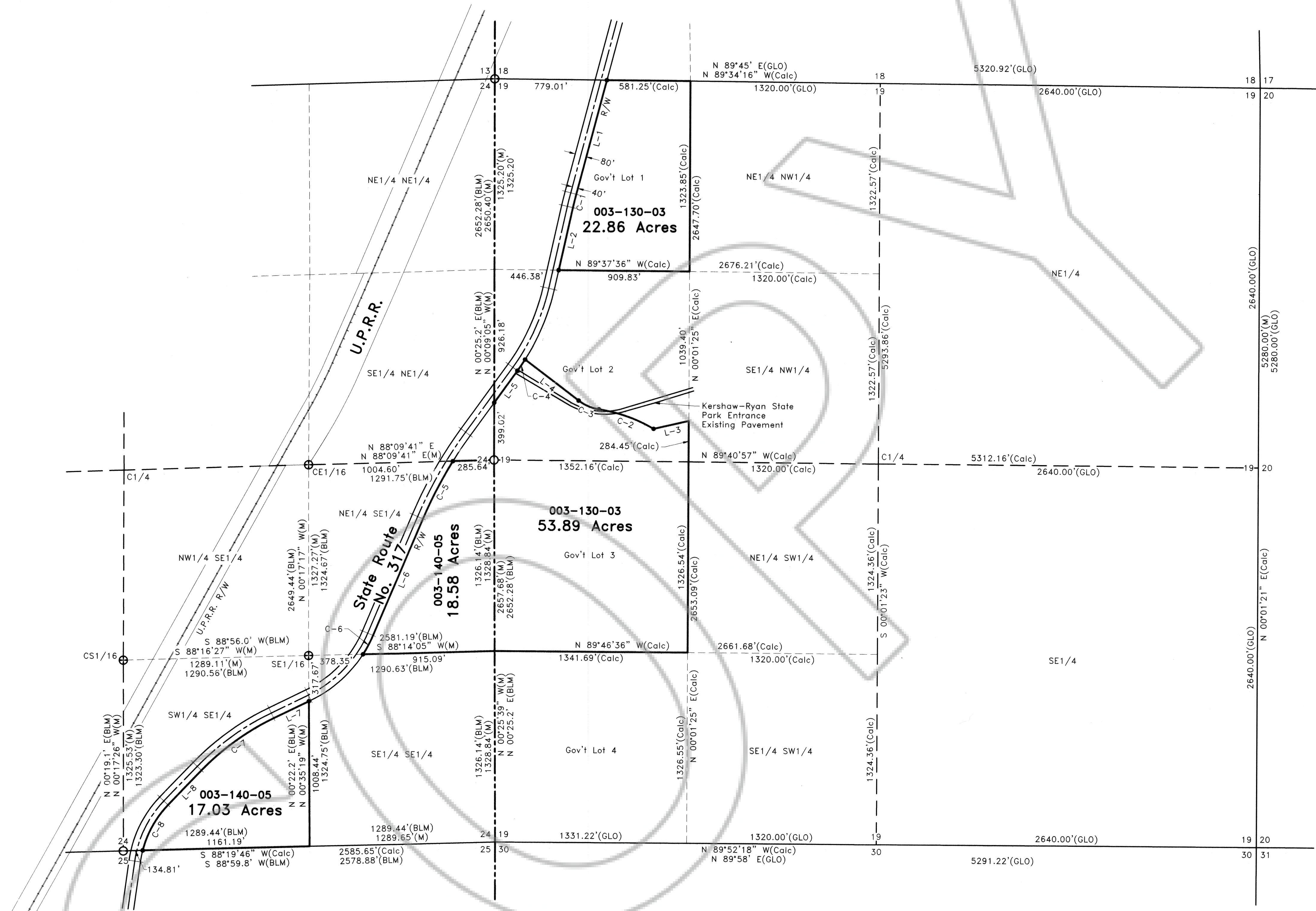

LINE DATA			
L-1	S 14°47'09" W	822.28'	
L-2	S 12°32'54" W	444.50'	
L-3	S 76°58'16" W	250.66'	
L-4	N 52°41'24" W	469.43'	
L-5	S 35°45'37" W	247.19'	
L-6	S 22°51'50" W	883.90'	
L-7	S 63°59'38" W	270.51'	
L-8	S 43°39'27" W	334.88'	

CURVE DATA				
CURVE	DELTA	RADIUS	TANGENT	LENGTH
C-1	02°14'15"	2460.00'	48.04'	96.07'
C-2	21°43'30"	1071.63'	205.64'	406.33'
C-3	28°36'50"	311.54'	79.45'	155.59'
C-4	03°32'19"	1540.00'	47.57'	95.11'
C-5	08°45'20"	2960.00'	226.60'	452.33'
C-6	09°34'36"	890.00'	74.55'	148.76'
C-7	20°20'11"	1760.00'	315.67'	624.69'
C-8	29°22'38"	710.00'	186.11'	364.04'

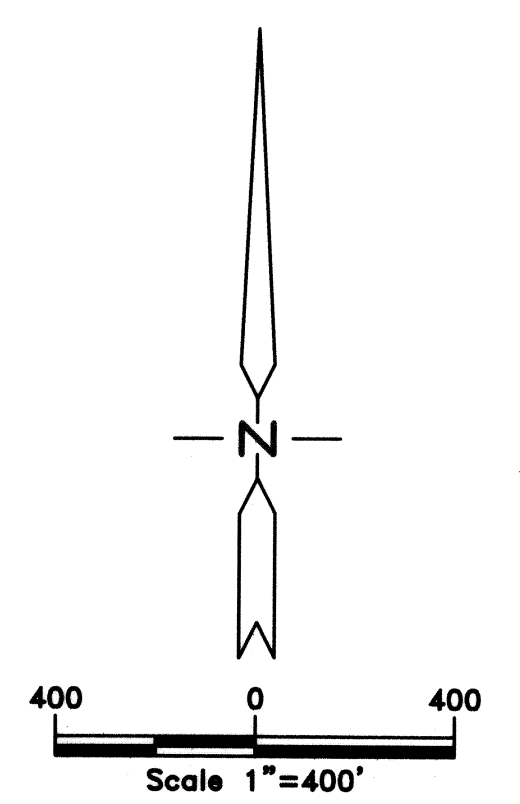

Sheet 4 of 6 Nev-265 S. Hafen

RECORD OF SURVEY
for
Rainbow Canyon Ranch, L.L.C.
Situated within Sec. 19, T. 4 S., R. 67 E., M.D.M., and
Sec. 24, T. 4 S., R. 66 E., M.D.M.,
Lincoln County, Nevada

THE OWENS SURVEYING OUTFIT, INC.
Water Right, Mineral & Land Surveying throughout the West

P.O. Box 540
99 W. Hollywood
Pioche, Nevada 89043
Tel : 775-962-5115
Fax : 775-962-5116

266-D

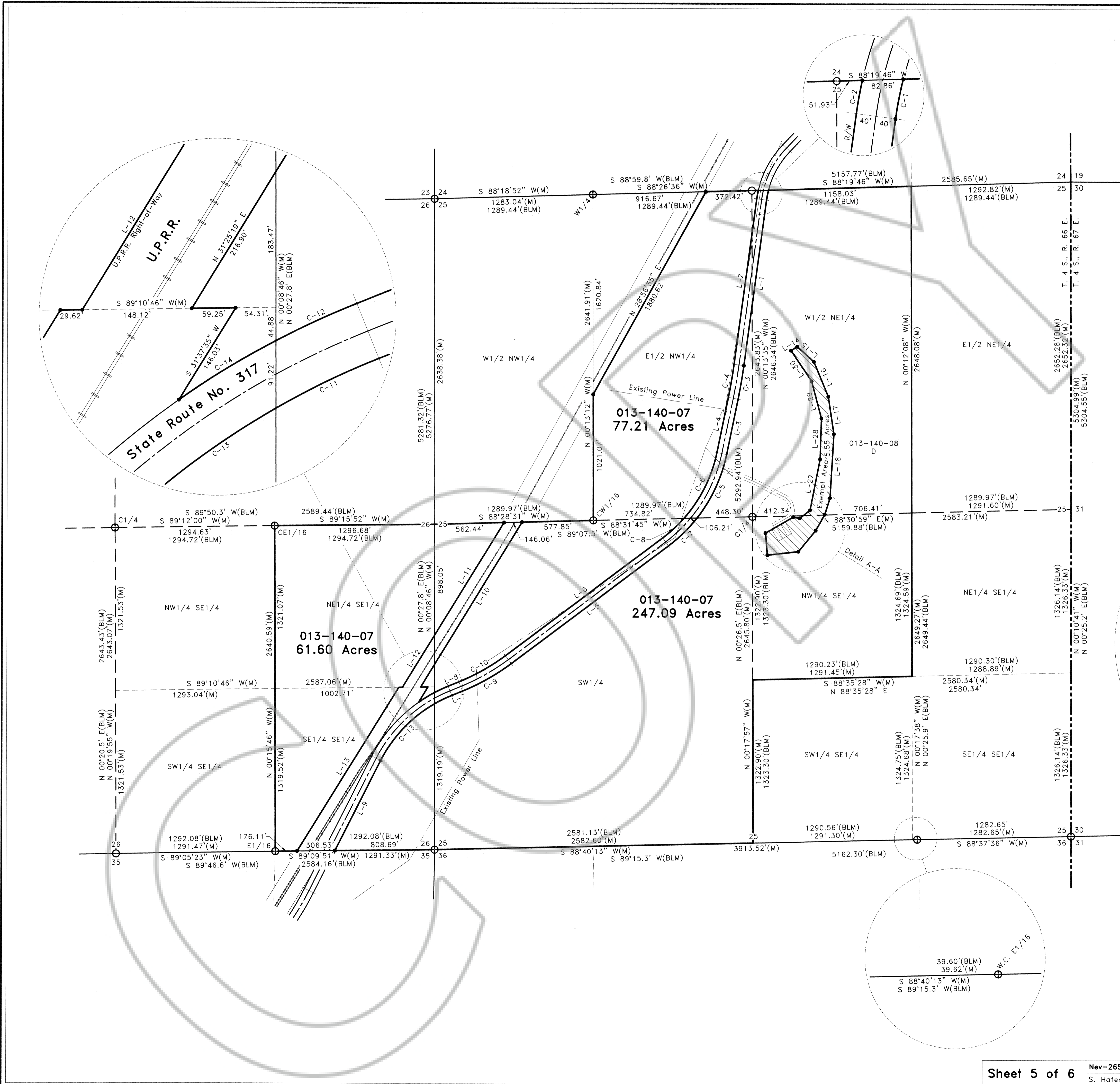

CURVE DATA				
CURVE	DELTA	RADIUS	TANGENT	LENGTH
C-1	06°36'29"	709.96'	40.99'	81.88'
C-2	04°57'24"	790.01'	34.19'	68.34'
C-3	03°55'03"	4040.00'	138.17'	276.23'
C-4	03°55'03"	3960.00'	135.43'	270.76'
C-5	26°26'05"	1240.00'	291.24'	572.10'
C-6	29°46'23"	1160.00'	308.36'	602.78'
C-7	14°58'46"	1240.00'	163.02'	324.19'
C-8	11°38'28"	1160.00'	118.25'	235.68'
C-9	15°00'32"	1740.00'	229.22'	455.80'
C-10	15°00'32"	1660.00'	218.68'	434.84'
C-11	07°58'59"	1110.00'	77.46'	154.66'
C-12	05°47'53"	1190.00'	60.26'	120.42'
C-13	33°18'20"	1110.00'	332.02'	645.23'
C-14	07°24'05"	1190.00'	76.97'	153.72'

LINE DATA		
LINE	BEARING	DIST.
L-1	N 07°40'04" E	1355.46'
L-2	S 07°40'04" W	1355.46'
L-3	N 11°35'07" E	457.88'
L-4	S 11°35'07" W	457.88'
L-5	N 52°59'58" E	1592.26'
L-6	S 52°59'58" W	1592.26'
L-7	N 68°00'30" E	92.98'
L-8	S 68°00'30" W	92.98'
L-9	N 26°43'11" E	820.60'
L-10	N 31°25'19" E	1352.98'
L-11	S 31°31'15" W	1071.05'
L-12	S 31°31'15" W	498.43'
L-13	S 31°38'42" W	1563.81'

AREA OF EXCEPTION LINE DATA		
LINE	BEARING	DIST.
L-14	N 57°22'26" E	59.75'
L-15	S 47°37'34" E	183.00'
L-16	S 22°37'34" E	306.00'
L-17	S 08°37'34" E	308.00'
L-18	S 03°22'26" W	518.00'
L-19	S 17°22'26" W	140.00'
L-20	S 29°22'26" W	150.00'
L-21	S 39°22'26" W	220.00'
L-22	S 83°19'18" W	253.33'
L-23	S 05°07'34" W	180.00'
L-24	N 60°00'07" E	259.75'
L-25	S 80°37'34" E	54.00'
L-26	N 52°22'26" E	104.00'
L-27	N 11°01'43" E	420.80'
L-28	N 01°47'43" E	331.10'
L-29	N 14°53'31" W	312.40'
L-30	N 33°53'38" W	300.36'

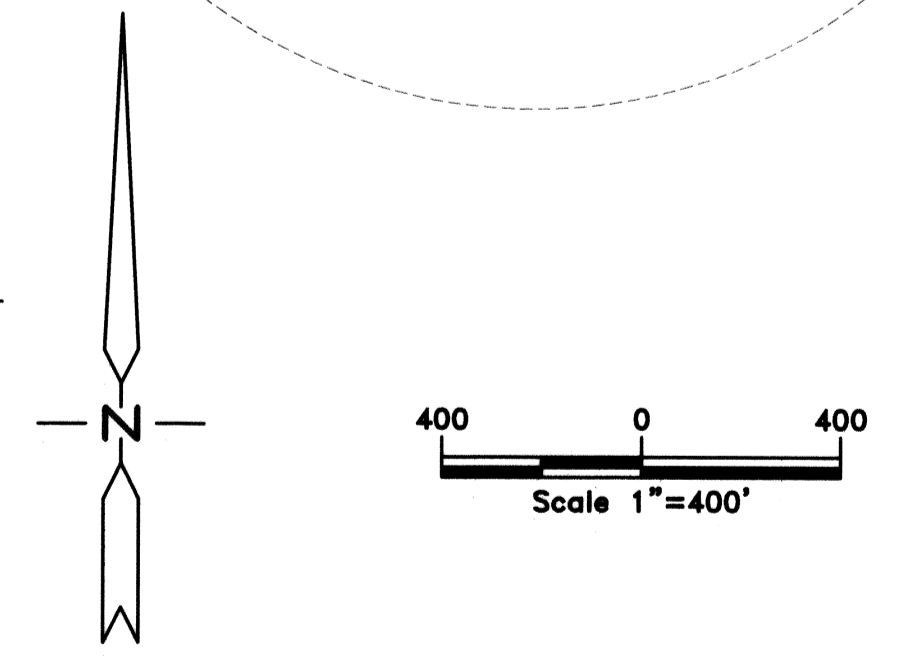
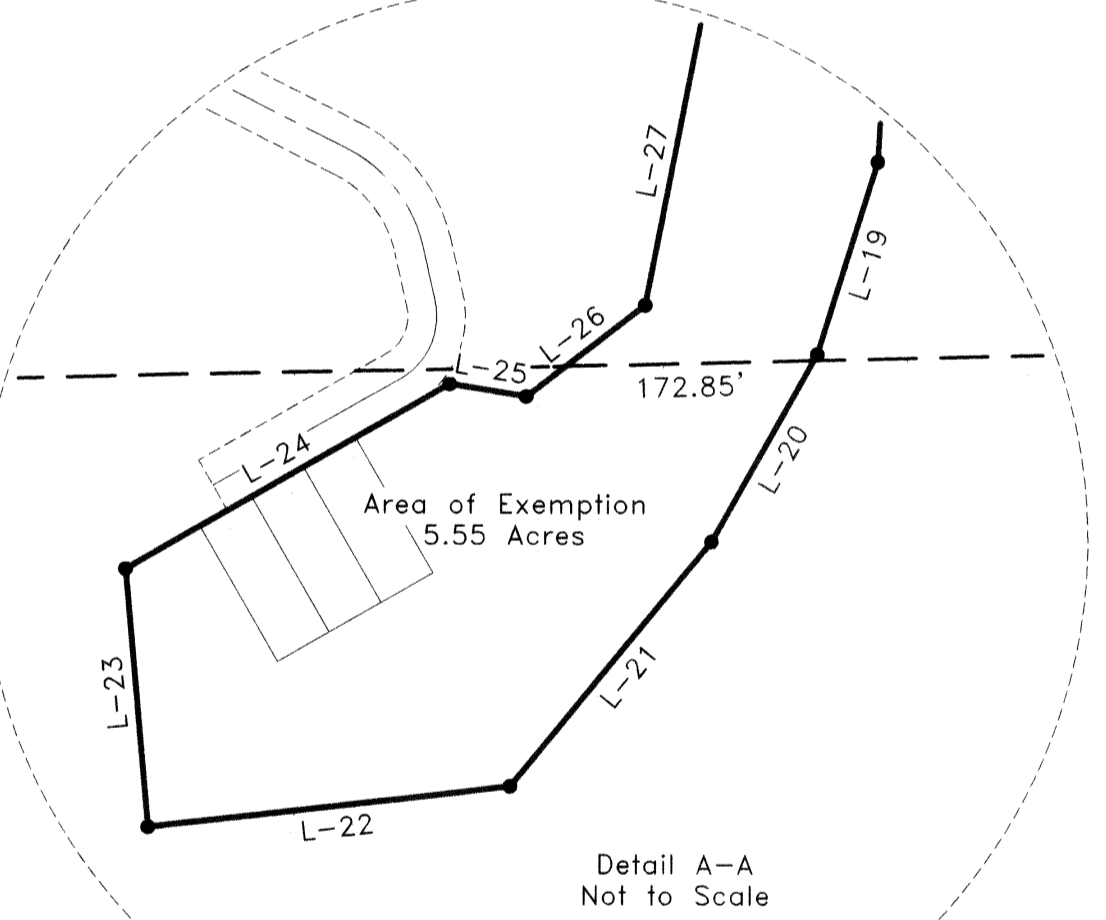

RECORD OF SURVEY
for
Rainbow Canyon Ranch, L.L.C.
Sited within Sec.'s 25 & 26, T. 4 S., R. 66 E., M.D.M.,
Lincoln County, Nevada

THE OWENS SURVEYING OUTFIT, INC.
Water Right, Mineral & Land Surveying throughout the West

P.O. Box 540
99 W. Hollywood
Pioche, Nevada 89043
Tel : 775-962-5115
Fax : 775-962-5116

